

Shimpo Instruments

Digital Torque Meter

Operations Manual

TNP Series



Contents

I. Introduction	2
II. What is the TNP Torque Meter?	3
III. Product Features.....	3
IV. Parts and Functions.....	4
V. Main Display (Description).....	5
VI. Secondary Functions	6
VII. Function Mode Table.....	7
VIII. Operation.....	11
XI. Zero adjustment / Tare the TNP	14
XV. Sample Applications	19
XVI.Specifications and Drawing	20
XVII.Other Shimpo Products.....	21

I. Introduction

Thank you for choosing the TNP Digital Torque Tester. With proper use and operation, this unit will provide many years of reliable service.

Upon receiving the unit, please check for any obvious physical damage that may result from shipping. If any damages found, please notify your carrier immediately before shipping back to Nidec-Shimpo America for inspections and possible repairs.

Contact Information:
NIDEC SHIMPO AMERICA CORPORATION
INSTRUMENTS DIVISION
1701 GLENLAKE AVENUE
ITASCA, IL 60143
(800) 237-7079

Each package includes the following:

- Operations Manual
- Software Installation Disk (Digitorg Software)
- Warranty Card
- USB A to USB B communication cable
- Universal AC adapter (100-240 VAC)
- Set of 30 mm chuck pins (4 pieces)
- TNP unit

Prior to operation read this manual carefully to understand and maximize the use of this Digital Torque Tester. Have this manual handy for future reference and information.

Observe the following important indicators.



Caution warning holds important safety information



Reminder: holds important key information for the product.

II. What is the TNP Torque Meter?

The TNP torque meter is a portable static torque measuring device that can be used as a quality assurance tool for various applications that require measurement of turning (both opening and closing) and twisting.

Some of the industries that can utilize this equipment are:

- Pharmaceutical
- Food/ Beverage
- Cosmetic products
- Packaging



Equipped with internal rechargeable batteries, the TNP can operate as a portable DC powered device or thru the universal AC adapter.

Designed with a small footprint it can easily be transferred to maximize use around the shop floor or the laboratory.

The programmable HI-LO set points make this unit ideal for pass-fail testing in a production environment.



Do not test products that are filled with liquid as the TNP torque tester is not protected from liquid spills.

III. Product Features

- High Accuracy: $\pm 0.5\%$ F.S.
- Wide Torque Range: 0.5Nm, 2Nm, 5Nm and 10Nm (available models)
- Adjustable Sample Size: 10-190 mm diameter (0.39"-7.48")
- Selectable units for measurement:
 - TNP-0.5 : mN-m, N-cm, g-cm, lb-in
 - TNP-2, 5, 10 : N-m, N-cm, kg-cm, lb-in
- Large Display: Easy to read digital display
- PC Output: USB interface with add in software (Digitorg)
- Flexible Power: Can run with built in rechargeable NiMH batteries or Universal AC adapter
- Selectable Measuring Modes: Captures Peak Opening, Closing and Average (CCW, CW)
- Portable: Small foot print, compact design, space saver
- Programmable HI and LO set points for Pass-Fail testing
- Store up to 1000 values into memory
- Selectable Display update time (8 times/second maximum)

IV. Parts and Functions

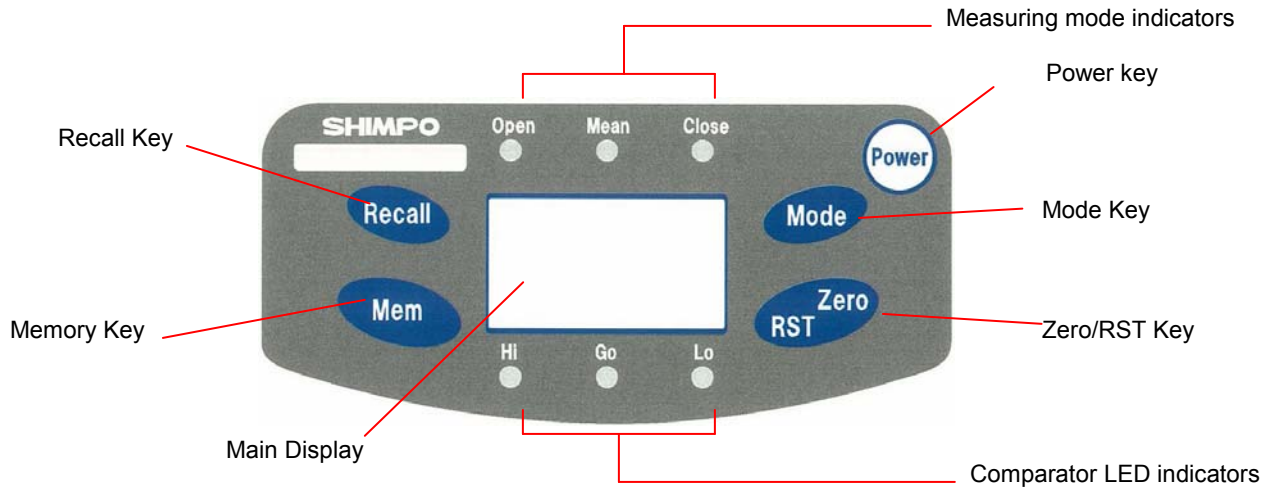

Parts	Functions/Description
Power key	Turns the unit ON and OFF.
Recall key	Recall data stored in OPEN and CLOSE modes. NOTE: in Average or Mean Mode, the Recall button has no function
Mem key	Memory key for storing data in Open and Close Modes. Note: In Mean mode the Mem key has no function. In this mode data cannot be stored in memory. Mem combined with another key is used in secondary functions. (Parameter and clear settings – see next section).
Mode key	Selects mode of operation (CLOSE, MEAN, and OPEN) Serves as an exit function when in Memory recall. Secondary function in parameter settings (see next section)
Zero/RST key	Tare or zero function for resetting and initializing values while in Average or peak mode. Secondary function in parameter settings (see next section)
Main Display	Displays measured values and status indicators, which includes units of measure, battery status and function status.
Measuring mode indicators	Red LED mode indicators. Informs which mode is selected “Open”, “Mean” or “Close”.
Comparator LED Indicators	Quick pass/fail visual indicators for all modes of measurement. The LED indicator does not light when comparator feature is OFF.

V. Main Display (Description)

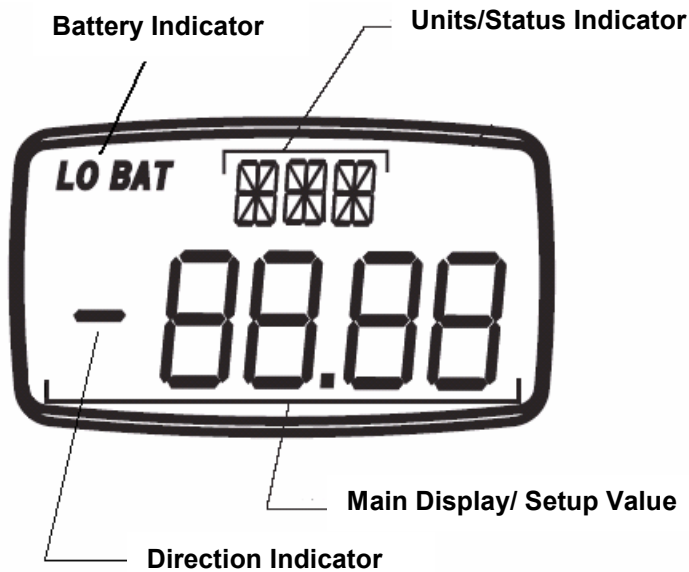

Extended Description

- **Units/Status indicator** – located on the upper part of the display this shows the current units of measure selected for the torque meter. It also serves as a sub display under function mode (F01, F02, F03, etc.)
Example: “OVR” indicates an overload condition the TNP went over its rated capacity. “PWR”, the auto power off feature is set this indicator serves as a 1 minute warning before the unit turns off.

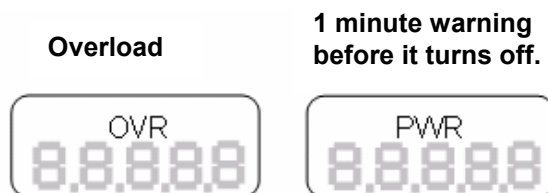

- **Main display/Set up Values** – shows the measured value in four digits including decimal places. While under function mode, this displays the options for each setting.
- **Direction Indicator** – indicates direction of applied torque based from F04 setting (Please see sign orientation information from function mode table). By default, closing indicates a negative “-“values; Opening “no sign”.

- **Battery Indicator** – shows the status of the TNP internal battery. “LO BAT” appears on the display to indicate a low battery status. “**BAT**” is shown when the TNP is charging. This indicator disappears when the battery is fully charged or when the AC adapter is disconnected from the TNP. It is important that the battery be cycled properly to achieve the maximum life from it.

VI. Secondary Functions

Parameter window settings: by using certain key combinations the parameter window can be accessed.

Operation key	Operation	How to operate
Zero/RST Power	Function mode	With Power off, press and hold the Zero/RST key then power ON the torque meter. Continue holding the ZERO/RST key until the display shows “ F01 ”, Pressing MODE changes the value of the selected function mode. Pressing the “ Zero/RST key ” advances from one parameter to the next. The lists of function are provided in the next section. (See picture below for additional description).
Mem Power	Clear memory data	With Power off, press and hold the Mem key , then power ON the torque meter. Continue holding the Mem key until “ none ” appears on the display.



This picture indicates the torque meter is in **Function Mode**.



If the display shows the normal operation of the torque meter, and no F01 is seen on the display, the Zero/RST key was released earlier than what is required. Turn off the torque meter and repeat the process.

VII. Function Mode Table

FUNCTION	Sub display	Options	Initial setting
Measuring unit	F01	Changes units of measure TNP-0.5 : mN-m, N-cm, g-cm, lb-in TNP-2, 5, 10 : N-m, N-cm, Kg-cm, lb-in	TNP-0.5 : mN-m TNP-2, 5, 10 : N-m
Display-(update rate)	F02	Switch 1, 2, 4, 8 times/second	2
Auto power OFF	F03	10 minutes or on	10 minutes
Sign Orientation	F04	-0000 CCW (Open "-"); 0000 CCW(Open "+")	0000
Upper comparator value (Hi limit)	HI	0000 – 9999: with decimal point. (Setting the values to zero disables this function) .	0000
Lower comparator value (Lo limit)	LO	0000 – 9999: with decimal point (Setting the values to zero disables this function).	0000

How to change value on the function selected?

To change the values of the function selected, use the Mode key button to scroll through the options and the Zero/RST button to move to the next Mode.



Pressing the Mode button after setting the HI/LO limits exits out of the function mode. You will need to reenter the settings to change additional values.

Operation diagram of how to access the Function Mode

Turn OFF the TNP before starting

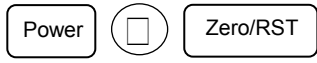

Press and hold the Zero/RST key
Power on then release the Power button
but continue to hold Zero/RST key until display F01

Function Mode – Measurement unit

TNP-2, 5, 10

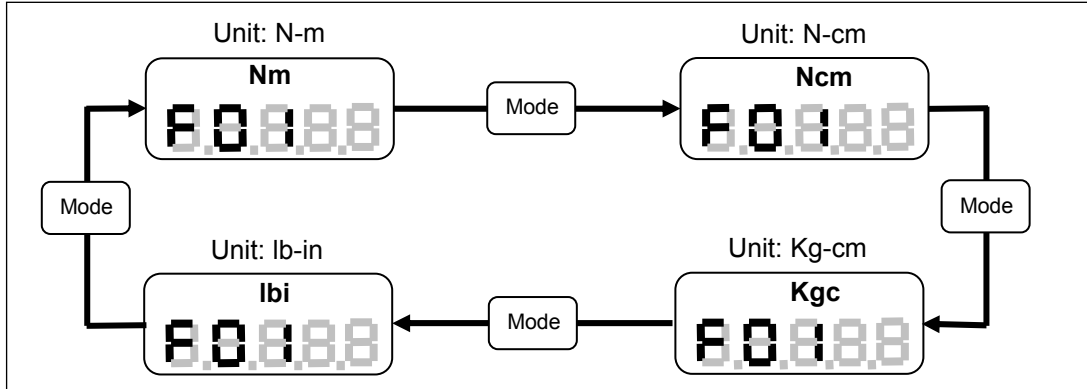

TNP-0.5

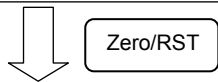
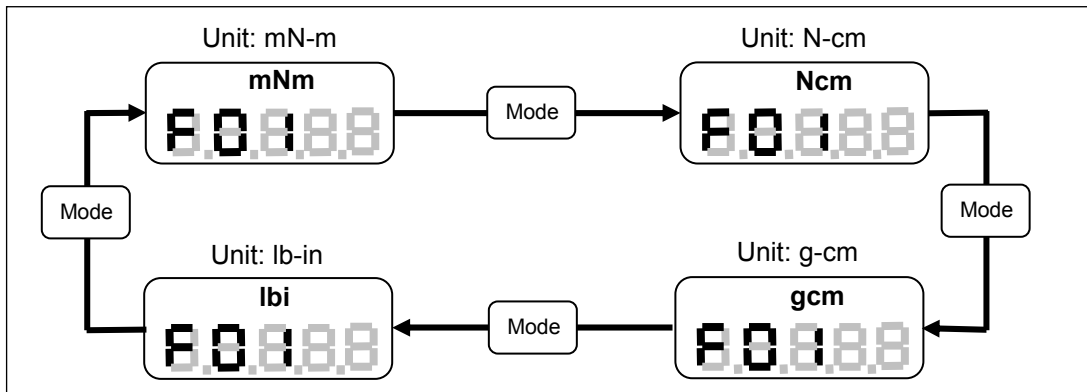

Pressing Zero/RST, it moves to the next function setting.



Use the MODE key to change values of each function.
Use the Zero/RST key for moving to the next function

Function Mode – Display (update rate)

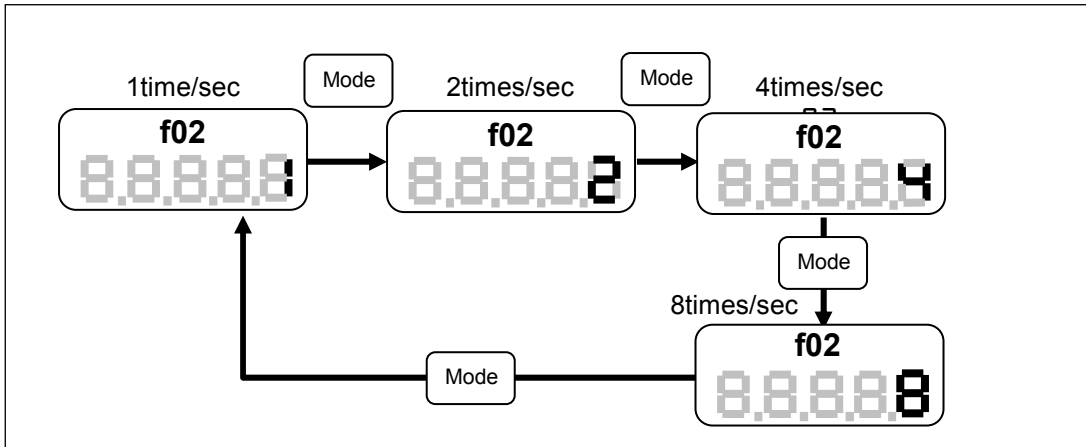

↓ Zero/RST Pressing Zero/RST, it moves to the next function setting.

Function Mode – Auto power OFF

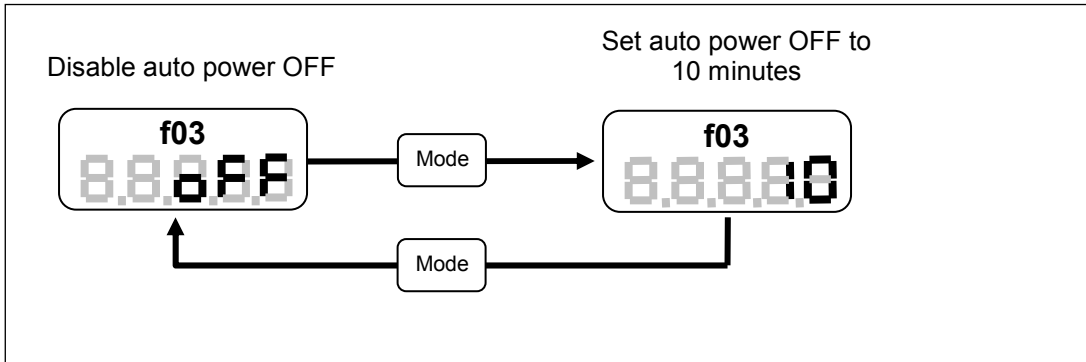

↓ Zero/RST Pressing Zero/RST, it moves to the next function setting.

Function Mode – Sign Orientation

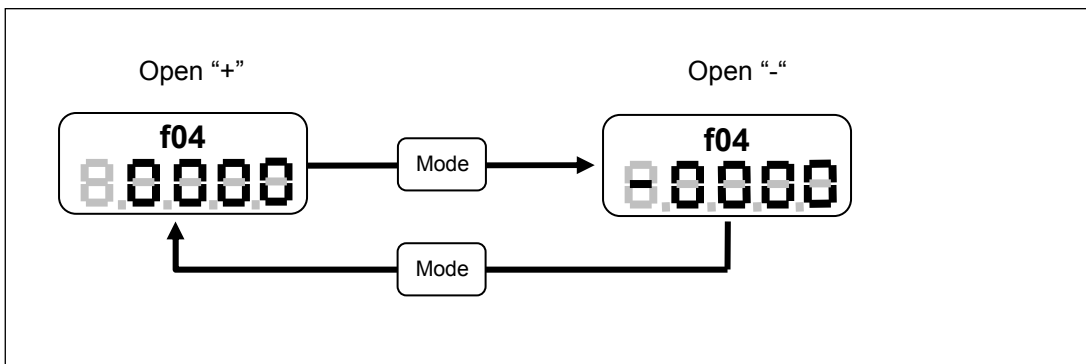

↓ Zero/RST Pressing Zero/RST, it moves to the next function setting.



Use the MODE key to change values of each function.
Use the Zero/RST key for moving to the next function

Function Mode – Upper comparator value (Hi Limit)

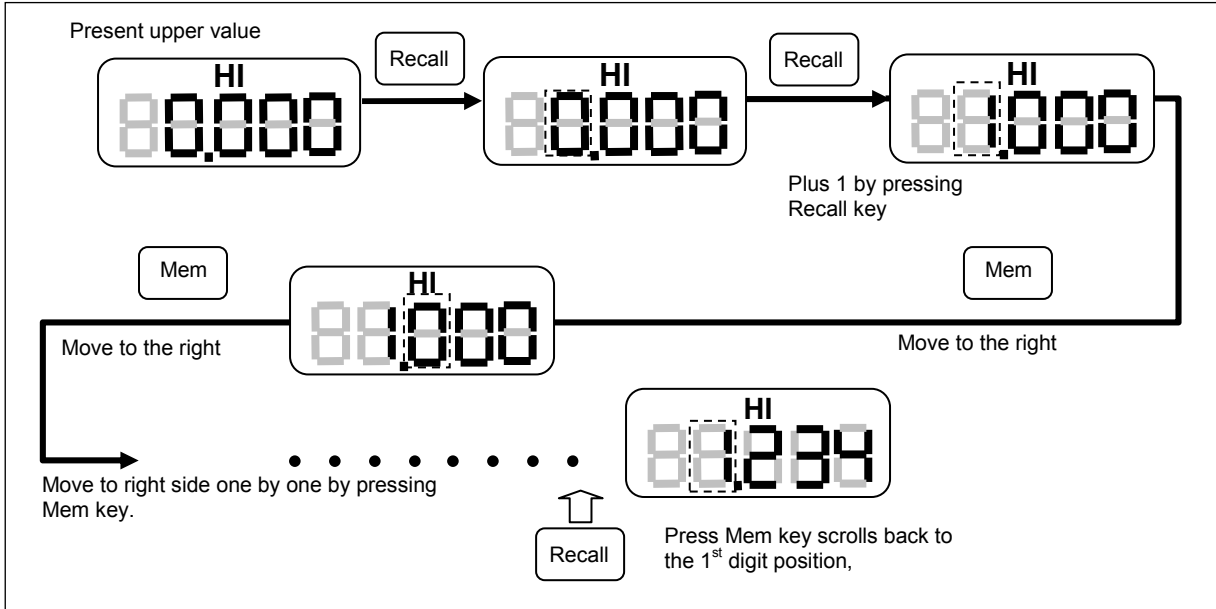

↓ Zero/RST Pressing Zero/RST, it moves to the next function setting.

Function Mode – Lower comparator value (Lo Limit)

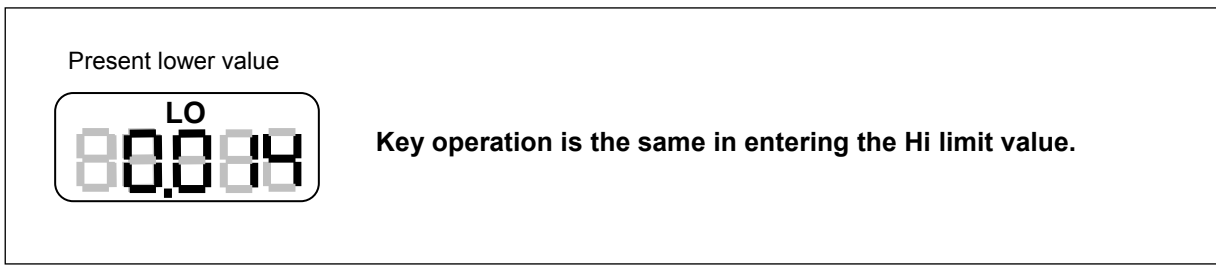

↓ Zero/RST

Move to setting register/ standard display



Use the MODE key to change values of each function.
Use the Zero/RST key for moving to the next function

VIII. Operation

Pretest Checklist:

Determine the size of the sample to be tested. Adjust the 4 jig on the testing table accordingly. Center the sample and use the knob to secure the sample in place (clockwise to tighten the jig to the sample material).



It is important to make sure that all the jigs are flush to the moving brackets. Each one of these jigs has set pins which slides into place inside the grooved brackets.

Measuring Modes

Measuring Modes available on the TNP: OPEN, CLOSE, MEAN

Select the measuring mode required for testing. Please check the settings below on how to select the right mode for testing.

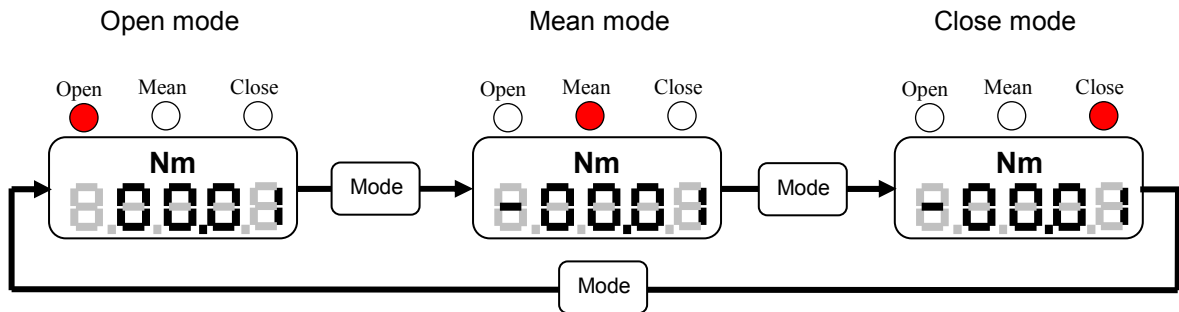

Pressing the Mode key toggles through the mode available from the TNP, LED indicators are provided to display current selected mode.

OPEN and CLOSE modes are PEAK Values captured by the TNP, these values are not real time values, and are retained on the display until one of the following occurs, the Zero/RST key is pressed or a higher peak value is detected (which in this case, replaces the current value detected).

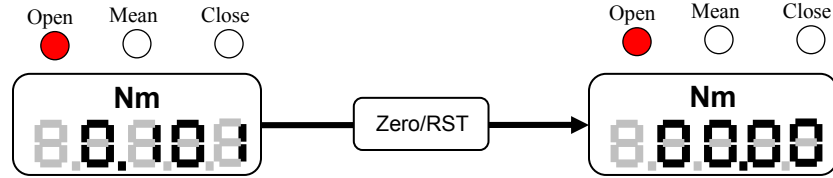

Resetting the Peak values to Zero

MEAN is real time value based on the average data captured in 1000 samples per second.



The maximum display update for all modes is 8 times/second. This update rate can be adjusted by changing F02 from function mode (See section VII - Values available 1, 2, 4, 8 times/second).

Comparator Function

This compares the measured value to the upper and lower limits entered under function mode for HI and LO limits.

If both HI and LO limits are set to "0000" this feature is not available (deactivated).

The following conditions are valid under comparator mode:

- HI>LO
- HI=LO (HI Red LED indicator will be lit on the Comparator LED indicators).

Utilizing this feature makes it an ideal tool for quality assurance checks.

Example: HI is set to 100 and LO is set to 50. Based from the conditions met the corresponding LED will light up (HI (Red LED), GO (Green LED), LO (Red LED)).

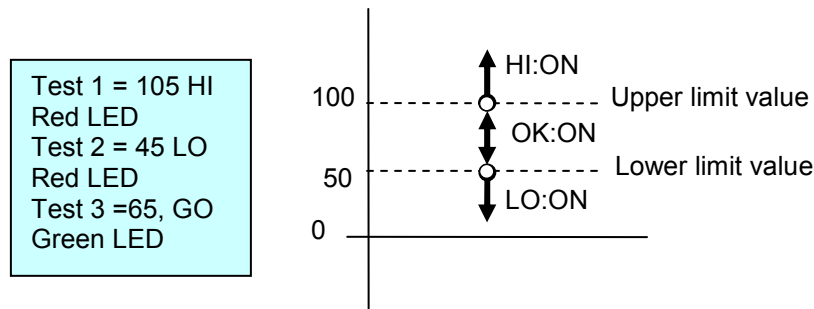

From the previous example any values greater than 100 will light up the HI red LED.

Any values lower than 50 will light up the LO red LED.

Values measured in between these values ($100 < X < 50$) will give a GO green LED indicator.

How to change the HI and LO values from the TNP torque meter?

- To set the HI and LO limits from the TNP torque meter access the function mode. (See section VII).
- Power off the torque meter
- Press and hold the Zero/RST key then power on the torque meter.
- Continue to hold on the Zero/RST key until the main display shows F01



- Press the Zero/RST key until the main display shows HI limit
- Using the Recall key we can increment the highlighted digit from 0-9.
- Press the Mem key to move from left to right or to the next digit.
- Entering values that are invalid the display will blink momentarily indicating wrong values entered to the HI and LO limits. (HI>LO, HI=LO).
After entering the LO limit value and pressing the Zero/RST button the torque tester will go back to normal operation.

XI. Zero adjustment / Tare the TNP

Taring or zeroing the value of the TNP initialize the torque meter to zero. This function is performed by pressing Zero/RST button on the front panel. In OPEN and CLOSE modes this zeros out the Peak values measured.



It is essential that the TNP be zeroed out before performing another test. This ensures that the TNP is properly initialized and no additional values are added to the measurement.

XII. Saving Data in Memory

Data can be stored in the TNP meter by pressing the Mem key. This feature is only available in OPEN and CLOSE measuring modes.

NOTE: In MEAN or Average mode the Mem key has no function.

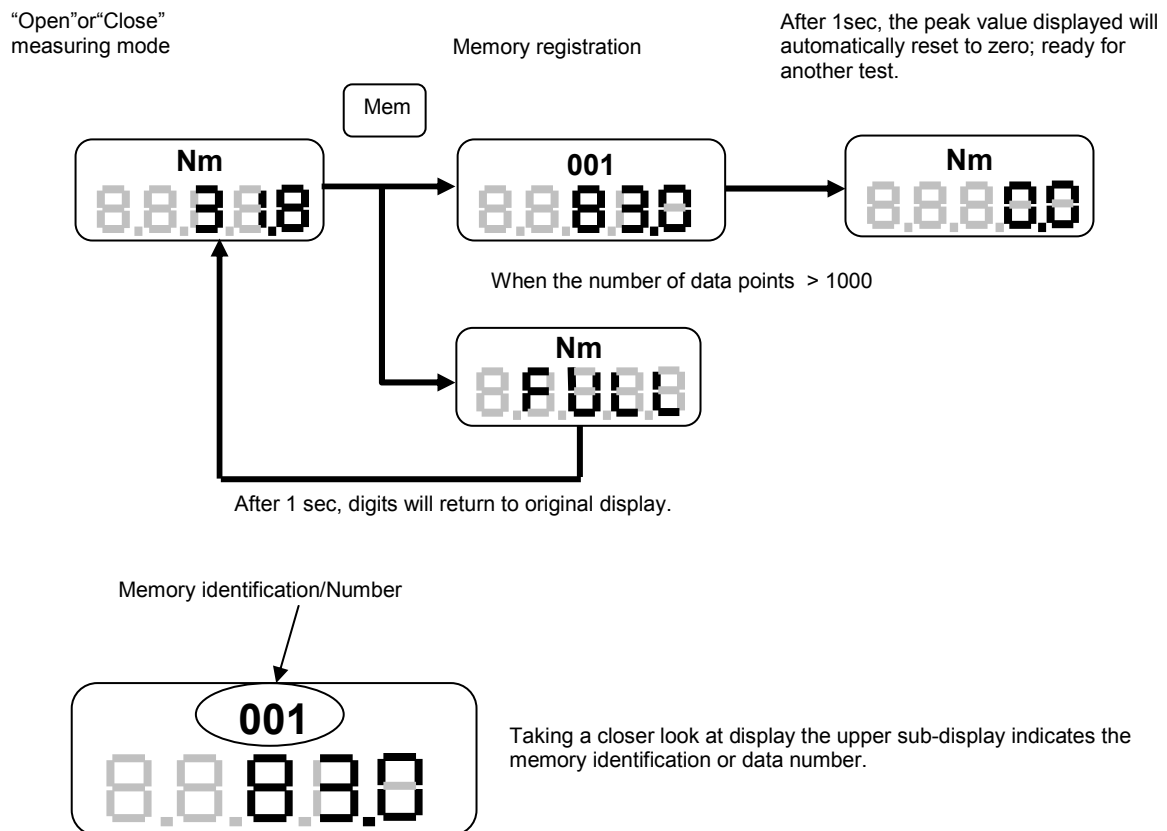

XIII. How to recall stored Memory

Select Open or Close Mode, press the Recall key and the display will indicate the number of data stored in memory.



Press Recall key second time to access the following information.

- AVERAGE Value
- MAX Value
- MIN Value
- Stored data (Data order of recall is based from the last data stored in memory)



Displays Max Values after pressing Recall

To access the stored measured value use the Recall key to scroll thru the values. (This will be after the MIN value is displayed). The display will flash two sets of numbers, the first number indicates the memory ID and the second number is the value stored on that memory ID.

NOTE: The order of values is from the last data stored to the first data stored. To review previous values shown, scroll through the values using the Recall key.



Picture above indicates the memory ID followed by the stored data. Pressing the mode button anytime exits out of the memory window. Below is a flowchart of how the recall function works.

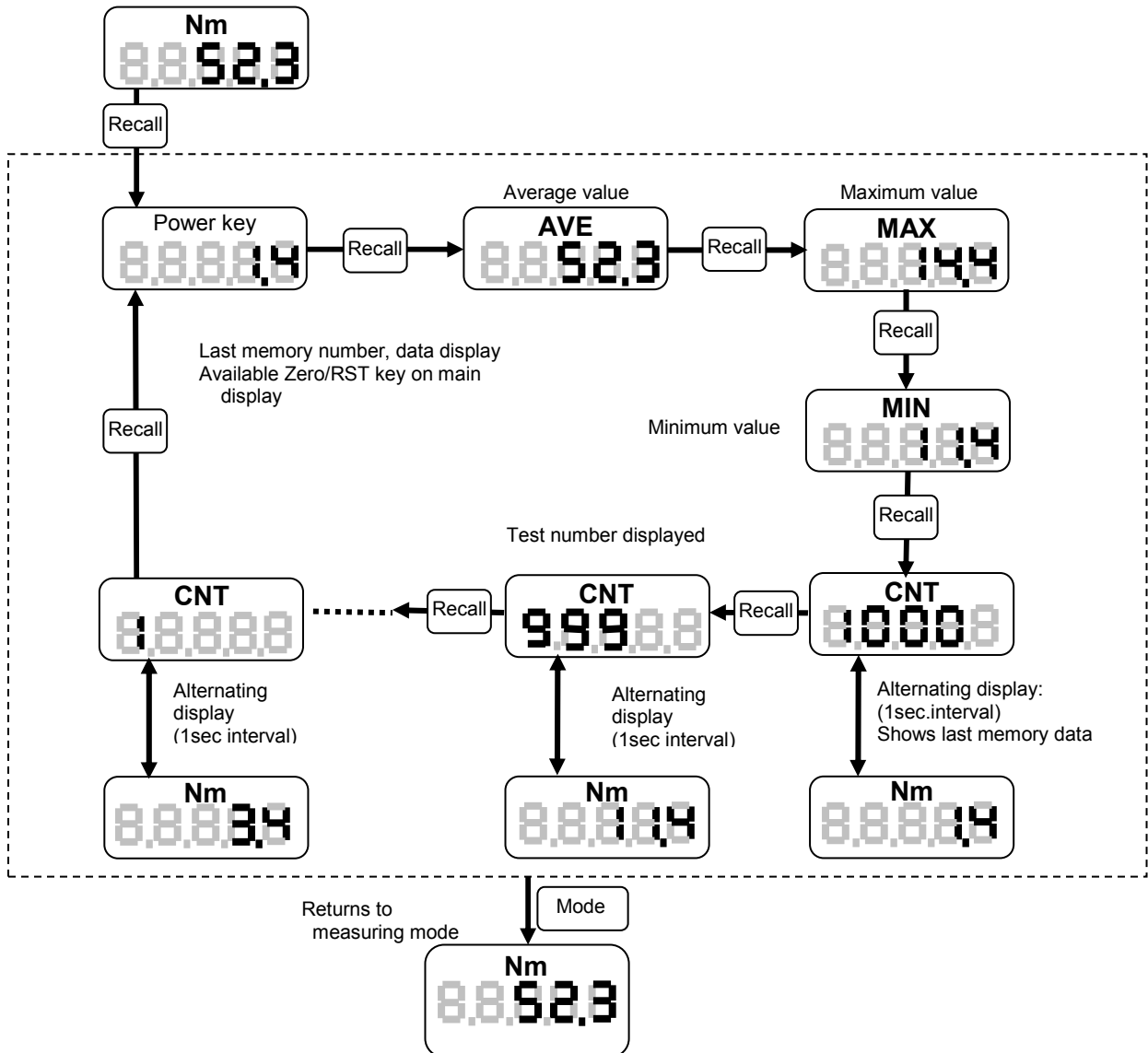

XIV. Clearing Stored Data

There are two types of memory clear available on the TNP torque meter.

- Single memory clear
- Clear all memory

Single Memory Clear

Single clear refers to erasing the stored data manually from the torque tester. The erase process starts from the most recent to the very first data stored.



Clearing data that is within the set cannot be accomplished by a single memory clear. The TNP does not allow the user to select the memory to be deleted. (jump out of sequence).

How does it work?

First select from Open or Close Modes (Mean or average mode data cannot be stored).

Press the Recall key to access memory, the first display you see will indicate the number of data stored in the torque tester and the last value saved.



Example from the picture above shows 3 data is saved (003) and the last value is 12.6. Pressing the Zero/RST button, the last data is eliminated (CLr will appear on the screen). Pressing the Zero/RST button again deletes the next data stored in the TNP torque meter.

Here is a flowchart of how the single clear works.

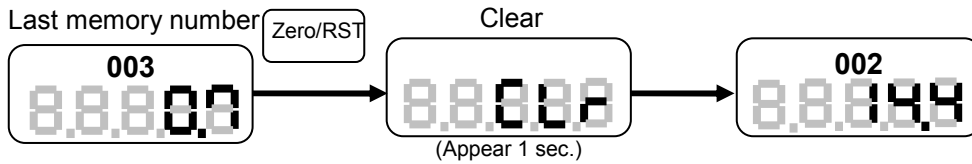

When there is one last data, the last data is cleared by pressing Zero/RST key. After that, “nonE” is displayed at main display for 2 seconds, then the display returns to measuring mode as shown below:

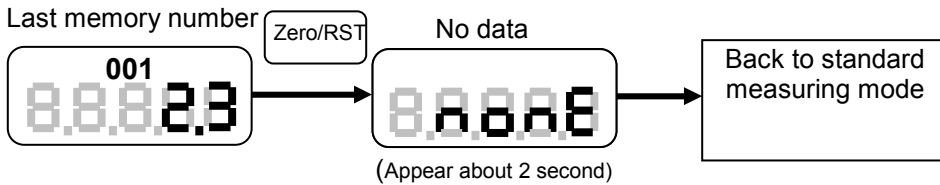

After all the data are erased pressing the Zero/RST button returns the display to normal measuring condition.

Clear all Memory

Clear all Memory or erasing all stored data in memory is possible by doing the following.

- Power off the TNP torque meter
- Press the **Mem** key and continue to hold this key while powering the torque tester. The TNP will initialize itself. You will see the model capacity displayed on the front panel then followed by the message “nonE”. This indicates that all data stored in memory have been erased or cleared.

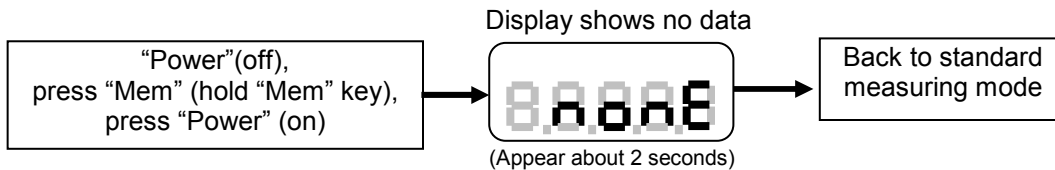

XV. Sample Applications



Beverage Cap Testing



Cosmetic Cap Testing



Camera Lens Zoom testing



Valve Open/Close testing



Torque Wrench application

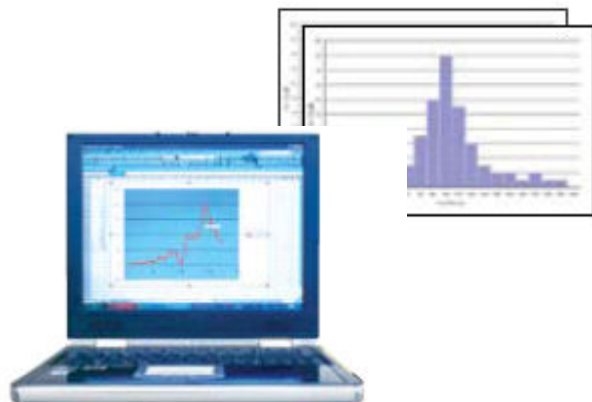

Application results can be downloaded via free software

XVI.Specifications and Drawing

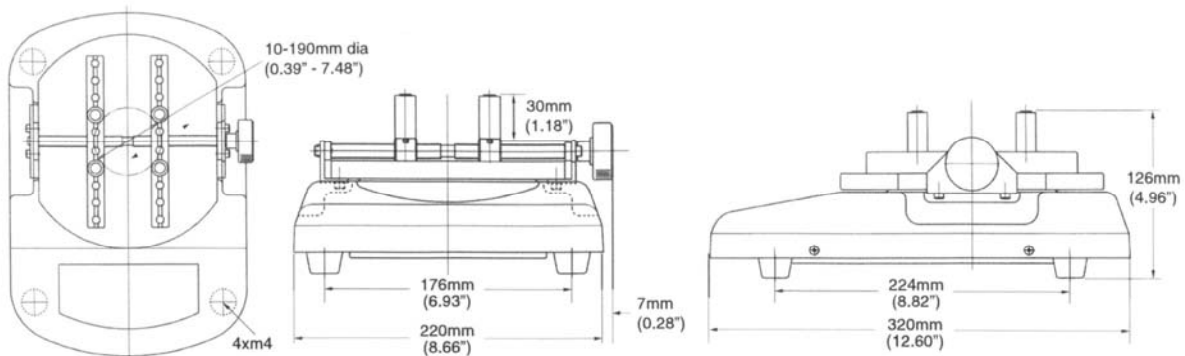

SPECIFICATIONS				
TNP- XX Series Digital Torque Tester w/USB interface				
TNP Models	TNP-0.5	TNP-2	TNP-5	TNP-10
Measuring units	Ncm, mNm, gcm, Lbin	Nm, Ncm, Kgcm, Lbin	Nm, Ncm, Kgcm, Lbin	Nm, Ncm, Kgcm, Lbin
Measuring range	0-50.00 Ncm	0-2.000 Nm	0-5.00 Nm	0-10.00 Nm
	0-500.0 mNm	0-200.0 Ncm	0-500.0 Ncm	0-1000 Ncm
	0-5099 gcm	0-20.39 Kgcm	0-50.99 Kgcm	0-102.0 Kgcm
	0-4.425 Lbin	0-17.70 Lbin	0-44.25 Lbin	0-88.5 Lbin
Overload protection / Percentage overload	150% of full scale			
Sample diameter range	Φ 10 - 190 mm (0.39 " - 7.48")			
Overload display	Display "OVR" at sub display of LCD, blinking LED			
Display	Main display	4-digit LCD display Character height 12mm		
	Sub display	3-digit LCD display Character height 7mm		
	Comparator Display	HI - GO - LO (green and red LED indicator)		
Accuracy	± 0.5% Full Scale			
Measuring	Opening mode	Show max value when opening (peak display) Displays max counterclockwise torque.		
	Closing mode	Show max value when closing (peak display) Displays max clockwise torque.		
	Average mode	Real time display (average value display) Displays torque in real time.		
Display Update Time	Select from 0.125 second (8 times/second), 0.25 second (4 times/second), 0.5 second (2 times/second), 1 second(1 time/second). Peak display: 0.125 second			
Sampling Rate	1000 times/second			
Memory	Memory data number	1000 data (max)		
	Statistical process	Average value, max value, min value		
Data output	USB1.1			
PC software	Digitorg software (free, download from web site: www.shimpoint.com)			
Standard Accessories	USB cable, 120/240 VAC AC adapter, 30mm chuck pin (4pcs), Manual			
Optional Accessories	Torque pins available: 30mm (4pcs) TNP-TP30, 50mm (4pcs) TNP-TP50			
Power	Built in nickel hydride battery or Auto-ranging AC adapter (AC100 - 240V)			
Dimensions L x W x H mm/ (in)	320 x 227x 126 (12.60" x 8.94" x 4.96")			
Shipping weight	8 kg (17.62lb)	8 kg (17.62lb)	8 kg (17.62lb)	12.5 kg (27.53lb)
Operation environment	0 - 40 degree C / 32 - 104 degree F			
Certifications	CE approval			
Battery Type/Battery Life	NiMH / 8 hours after full charge			
Battery Recharge Time	Max. 16 hours			

XVII. Other Shimpo Products

Please check Our website for other Shimpo force and Speed Products
www.shimpoinst.com

Force Products



Digital Force Gauges



Mechanical Force Gauges



Motorized Test Stands



Manual Test Stands



Attachments & Accessories



PT Kits

Speed Products



Stroboscopes



Handheld Tachometers



Panel Mount Tachometers



Panel Mount Counters



Sensors