

SHIMPO

Model FGS-50VB-H, and FGS-50VB-L Programmable Motorized Test Stands

Congratulations on your purchase of the of the FGS-50VB series Shimpo test stand. This manual explains how to operate your equipment safely and correctly.

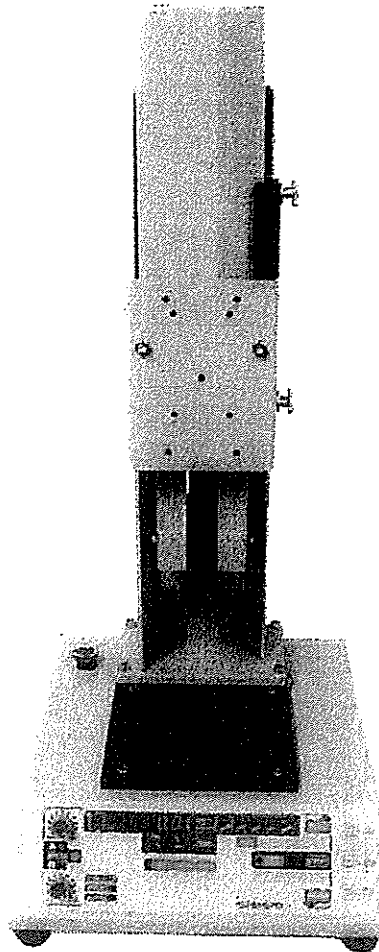

Read the entire instruction manual before initial set-up and operation; the information contained herein will help you in operating your Shimpo Programmable Motorized Test Stand.

A Tradition of Excellence
SHIMPO

A Ferris Group Company

Table of Contents

1.0 Features and Benefits	3
2.0 Important Safety Instructions	4
3.0 Set Up Procedures	4
4.0 Display Panel	7
5.0 Operation	8
5.1 Manu (Manual Mode)	8
5.2 Jog (Jog Mode)	9
5.3 Sing (Single Mode)	10
5.4 Cont (Continuous Mode)	11
5.5 Prog (Program Mode)	13
6.0 RS232C Output Format	17
7.0 Troubleshooting	19
8.0 Test Stand Specifications	21
9.0 Test Stand Dimensions and Drawings	22

For questions and inquiries regarding our product(s), call your local Shimpo representative or contact Shimpo Instruments directly for assistance



Caution warning holds important safety information



Reminder: holds important key information for the product.

Warranty

LIMITED EXPRESS WARRANTY

Shimpo Instruments warrants, to the original purchaser of new products only, that this product shall be free from defects in workmanship and materials under normal use and proper maintenance for one year from the date of original purchase. This warranty shall not be effective if the product has been subject to overload, misuse, negligence, or accident, or if the product has been repaired or altered outside of Shimpo Instruments's authorized control in any respect which in Shimpo Instruments's judgment, adversely affects its condition or operation.

DISCLAIMER OF ALL OTHER WARRANTIES

The foregoing warranty constitutes the **SOLE AND EXCLUSIVE WARRANTY**, and Shimpo Instruments hereby disclaims all other warranties, expressed, statutory or implied, applicable to the product, including, but not limited to all implied warranties of merchantability and fitness.

LIMITATION OF REMEDY

Under this warranty, Shimpo Instruments' **SOLE OBLIGATION SHALL BE TO REPAIR OR REPLACE** the defective product or part, at Shimpo Instruments' option. Shimpo Instruments reserves the right to satisfy warranty obligation in full by reimbursing Buyer for all payments made to Shimpo Instruments, whereupon, title shall pass to Shimpo Instruments upon acceptance of return goods. To obtain warranty service, Purchaser must obtain Shimpo Instruments's authorization before returning the product, properly repackaged, freight pre-paid to Shimpo Instruments.

INDEMNIFICATION & LIMITATION OF DAMAGES

Buyer agrees to indemnify and hold Shimpo Instruments harmless from and against all claims and damages imposed upon or incurred arising, directly or indirectly, from Buyer's failure to perform or satisfy any of the terms described herein. In no event shall Shimpo Instruments be liable for injuries of any nature involving the product, including incidental or consequential damages to person or property, any economic loss or loss of use.

MERGER CLAUSE

Any statements made by the Seller's representative do not constitute warranties except to the extent that they also appear in writing. This writing constitutes the entire and final expression of the parties' agreement.

Inspection/Standard Accessories

If any shipping damage is detected upon receiving the test stand, please do not unpack the unit. Notify your shipping carrier immediately for damage claim instructions.

Refer to the nameplate located on the back of the test stand to confirm model number ordered. Record serial number for future reference.

Model	Speed
FGS-50VB-L	5 - 120 mm/min
FGS-50VB-H	20 - 500 mm/min

- (3) M5 x 6 screws
- (1) 5mm Allen wrench
- (4) M4 x 8 screws
- Manual
- Analog Cable
- (1)M6 Set Screw
- (2)M6 Socket bolt
- (2)M6 Flat Washer
- (1)Cable Clip
- Communication Cable for FGC/FGP

1.0 Features and Benefits

Shimpo's FGS-50VB-H/L offers:

Programmable Motorized Test Stand

- *All steel construction which guarantees durability and stability for production, laboratory and quality control applications*
- *Dual speed controls are optimally positioned to adjust test and return travel rates of the drive assembly.*
- *Drive assembly accepts a universal mounting plate, enabling the interfacing of a large selection of force gauge models (contact Shimpo for specific models)*
- *4½ digital LED display indicates displacement rate and distance of the drive assembly.*
- *Analog output (10mV/mm) is convenient for data acquisition requirements.*



To switch from English to metric units, push "Speed" and "RST" button while turning the power on. To return to English units turn the stand off and push "SPEED" and "Time/>" buttons while turning the power back on.

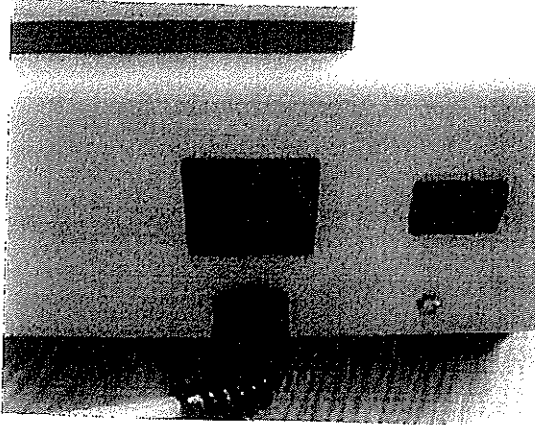

AC Power cord and AC plug for the Force gauge, located on the back of the rear of the test stand

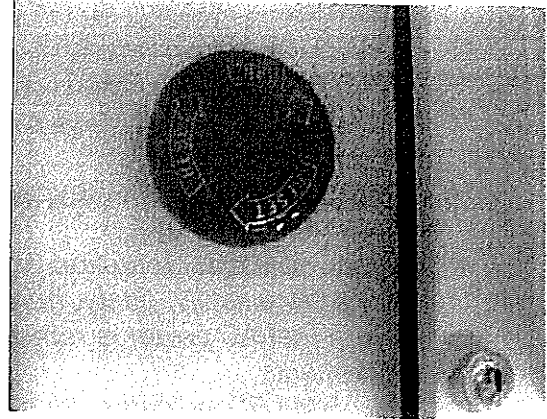

Emergency Stop button located on the side of the test next to the column. Turn the button Clockwise to release.

To identify whether the stand is in metric or English units, turn the power on. (power SW is located in the back of the unit), Metric units will show one decimal place (0.0), while English units show two decimal places (0.00) To change to metric units, push "A/SPEED/B" and "RST/^" switches while turning

2.0 Important Safety Instructions



Read this section carefully before initial set up.

- Position test stand on a level, heavy-duty table.
- Confirm that the test stand case is properly grounded to the AC line.
- Keep hands, hair and jewelry away from stand when drive assembly is in motion.
- Operate the membrane keypad with care. Do not use sharp objects that may puncture the overlay.
- Always wear eye protection when testing materials.
- Do not store in oily, dusty, humid or wet areas.
- Ensure that AC power is removed from test stand before making any adjustments.
- If ALARM LED indicates drive assembly has been overloaded, immediately switch the power switch to the off position and correct the overload condition. Wait at least two minutes before restarting the test stand.

3.0 Set up Procedures

1. Connect all the necessary cables and AC cord before applying power to the test stand.
2. Turn on the force gauge before applying power to the test stand; this is necessary to allow the test stand to recognize the attached Shimpo force gauge.
3. The power switch for the test stand is located on the rear of the unit. After power is applied, all the segments and LEDs will execute a power up, self test. After the self test, the test stand will display 0.00 (inches - English) or 0.0 (mm – metric).



If after power up the test stand takes longer to initialize and a “no_F” display is observed from the display, check the force gauge communication cable and the baud rate setting for the attached force gauge. The FGS-50 VB test stands communicate at 19200 baud rate for FGC/FGP.

the power on. To change to English units, push "A/SPEED/B" and "TIME/⟨" switches while turning the power on.



Caution warning holds important safety information



Reminder: holds important key information for the product.

Clearance Adjustment

You can easily adjust the clearance (the distance between the force gauge adapter and test sample) by adjusting the drive assembly in six 30mm increments

1. Position the test stand on its side with the cable ports facing up.
2. Loosen the three slot bolts, but do not remove them (this helps in sliding the test stand motor position easily).
3. Remove the set bolt (bolt insert on the column) and adjust the drive assembly to the desired clearance. Reinsert the bolt and tighten all the four bolts.

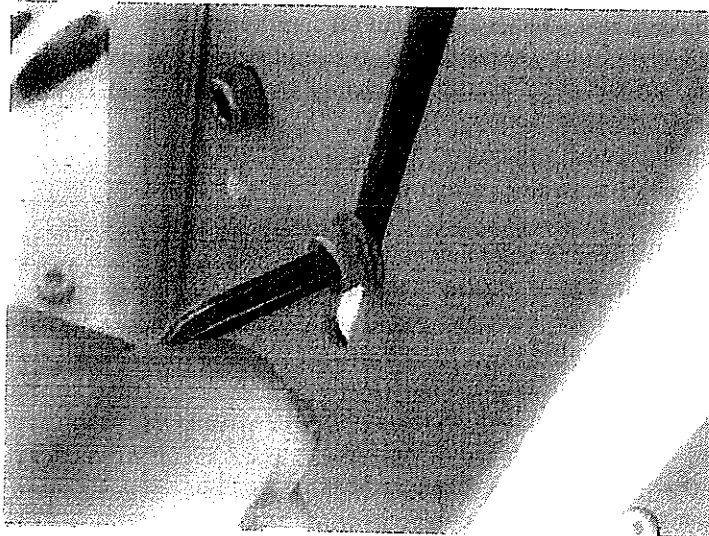

4 Allen bolts holding the drive assembly in place, use the 5 mm Allen wrench for adjustments.



When adjusting the position of the drive assembly, make sure that the cables from the motor are not pulled too far as to damage any connections.

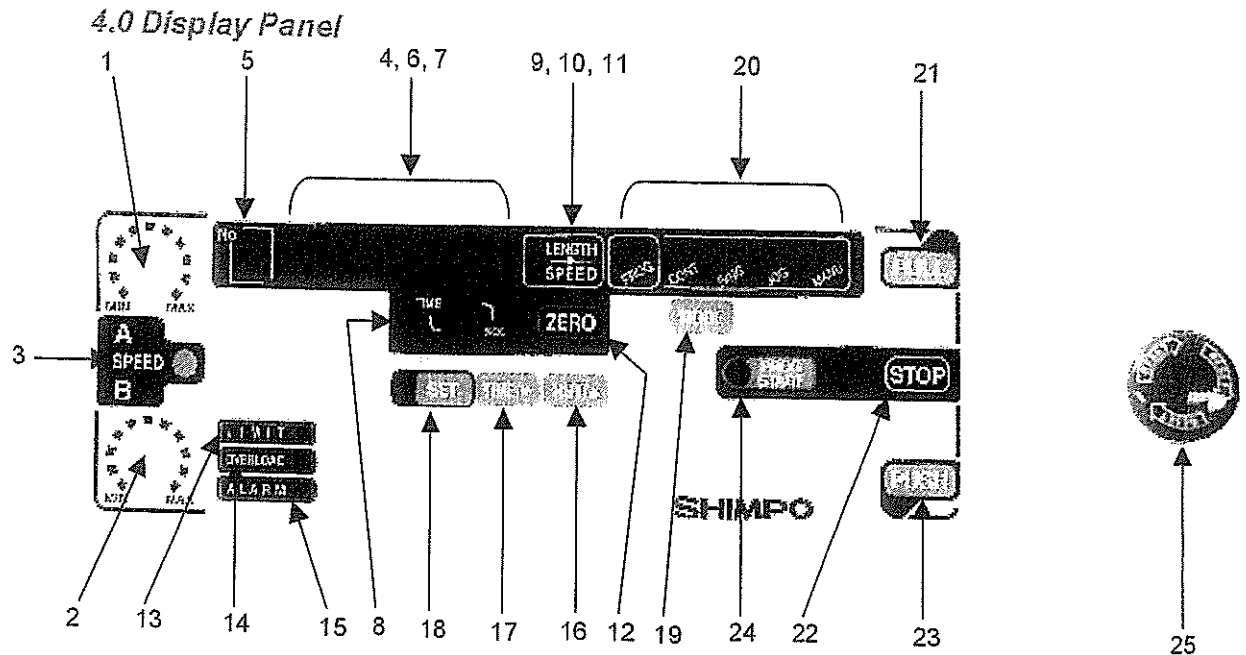

Figure 1

1. A Speed: Changes the upward speed.
2. B Speed: Changes the downward speed.
3. Speed: Selects speed control knob A or B.
4. Length, Speed or Cycle Display: Displays length, speed or cycle of a program when power is on. Note: Cycle Display can only be selected in mode SING, CONT or PROG.
5. No: Displays program cycle (0-9).
6. ▲:Indicates high limit value in all modes.
7. ▼:Indicates low limit value in all modes.
8. TIME: Displays programmed delay time between program cycles.
9. LENGTH, SPEED, or Cycle: Selects display of length, speed or cycle of a program.
10. LED LENGTH Indicator: Indicates that length is being displayed.
11. LED SPEED Indicator: Indicates that speed is being displayed. Cycle display is indicated when both Length and Speed LED's are off.
12. ZERO: Resets length measurement to zero.
13. LIMIT LED: Indicates one of the manual limit switches has been tripped.
14. OVERLOAD LED: Indicates that the force gauge has been overloaded.
15. ALARM LED: Indicates test stand's motor has been overloaded.
16. RST ▲:Changes the increment point upward.
17. TIME ►: Changes digit position when programming force limits, also changes delay between cycles.
18. SET: Stores a program cycle to a value that the user selects using RST/▲ and TIME/►.

19. MODE: Selects mode of operation: Manual, Jog, Single, Continuous or Program.
20. Operation Display: Informs user of current mode of operation.
21. PULL: Test stand moves in an upward direction.
22. STOP: Stops test stand movement.
23. PUSH: Test stand moves in a downward direction.
24. PROG START: Start the program.
25. Emergency Stop (located on the top of the test stand)

5.0 Operation

5.1 MANU (Manual Mode)

This mode of operation is ideal for manually recording force measurements. The test stand will only operate between the limits that are set by the test stand user. These limits can be either manually adjusted (distance limits) or programmed force limits when a Shimpo force gauge is used.

In this mode of operation the user can display length or speed. Display length by pressing the "LENGTH/SPEED" button until the LED adjacent to the indicator "LENGTH" is illuminated. To display speed, push the "LENGTH/SPEED" button until the LED adjacent to the indicator "SPEED" is illuminated.

To manually adjust distance limits, partially unscrew each of the two knobs on the metal plates that prevent the test stand platform from moving up or down. Adjust the lower knob to set the upper distance limit and the upper knob to set the lower distance limit. Tighten the knobs after limits are set.

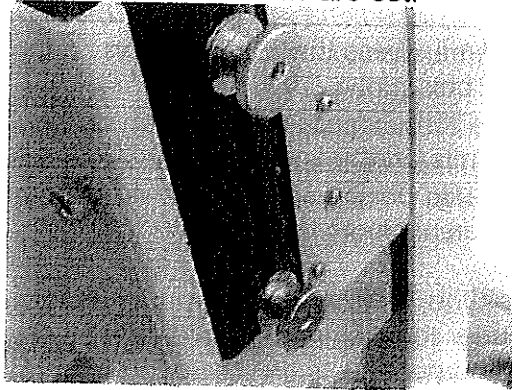

Limit switch knobs located on the side of the drive assembly



Make sure the proper limit knobs are set for upper and lower limit switch.

Upper limit is set by the LOWER knob

Lower limit is set by the UPPER knob

If using a ShimpoFGC/FGP model force gauge, you may set a force limit from the test stand. For FGX force gauges you will need to know the specific distance to conduct the test

How to do this?

First make sure that good communication exists between the force gauge and the test stand.



Remember to activate the force gauge first before turning on the test stand. This will ensure that the test stand recognizes the attached force gauge.

If theFGC/FGPforce gauge is not connected with the connection cable, the limit force setting from the test stand is not available.

If using the FGX force gauge model, the limits are set from the force gauge itself (HI/LO function). To stop the stand you will need the special cable to send the comparator out from the force gauge to the test stand.

To program a force limit, press the "SET" button on the front panel display. Note that the display "No" box shows "F◆". The "F" and the two arrows indicate that it is ready to accept the force limits for both push and pull operation. (The programmed force limits are the same for JOG and SING modes.) Use the "TIME/>" to change digit position and "RST/^" to increment each digit until the desired limit force is displayed.



Press the "TIME/<" button until no digits are blinking. This allows the user to select a negative sign by pressing the "RST/^" button. With no negative sign displayed the test stand force limit is programmed as a compression force limit, with the negative sign displayed the test stand force limit is programmed as a tension force limit. Select "SET" to store the force limit in memory.

The test stand will move in the downward or upward direction when the respective "PUSH" or "PULL" button is selected. The stand will continue to move in the selected direction until one of the following events occurs. The "STOP" button is pushed, one of the manual limit switches are tripped, the emergency reset button is pushed, or if the force limit is reached.

Note: In this mode of operation, no RS232C output is produced.

5.2 JOG (Jog Mode)

This mode of operation is identical to "MANU", except that the movement in any direction will only occur while the "PUSH" or "PULL" buttons are depressed.



Note: In this mode of operation, no RS232C output is produced

5.3 SING (Single Mode)

This mode of operation is ideal for completing one cycle between manual distance limits and/or force limit. The initial starting direction can be either in the tension or compression direction depending on whether the "PULL" or "PUSH" buttons are pressed.

If using a ShimpoFGC/FGP model force gauge, you may set a force limit.



To program the force limit, press the "SET" button on the front panel display while in the "SING" mode. Note that the display adjacent the "No" box shows "F \diamond ". Use the "TIME" and "RST" buttons to select the desired force limit.

Press "SET" to store the force limit into memory.

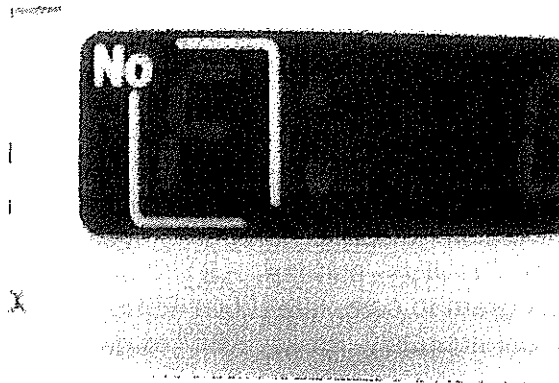

Front panel display indicating force limit for both direction.

A time delay in seconds can be programmed between changes in directions by cycling the "TIME" button through "0", "1", "2", "3", "4", "5".

In this mode of operation the user can display length, speed or cycle count. Display length by pressing the "LENGTH/SPEED" button until the LED adjacent "LENGTH" is illuminated. To display speed, push the "LENGTH/SPEED" button until the LED adjacent "SPEED" is illuminated. Finally, to display cycle count,

press the "LENGTH/SPEED" button until there are no LED's illuminated. When the stand platform is moving in the "down" direction the LED next to "SPEED B" is active. When the stand is moving in the "up" direction the LED next to "SPEED A" is active.

The test stand will move downward or upward when the respective "PUSH" or "PULL" button is selected. The stand will continue to move until one of the following events occurs. The "STOP" button is pushed, one of the manual limit switches are tripped, the emergency reset button is pushed, or if the force limit is reached.



Note: An RS232C output is produced when using this mode of operation; see RS232C Output Section 6.0 for details.

5.4 CONT (Continuous Mode)

This mode of operation is ideal if the user wants the test stand to repeatedly cycle up and down continuously or for a user-programmed number of times. The stand will start in either direction depending on whether "PUSH" or "PULL" is selected.

Length, speed or cycle count can be displayed as described in 5.3 SING mode of operation.

To begin programming the test stand, press the "SET" key. The display will indicate a "C" in the "No" box. The "C" designates that the digits programmed into the adjacent LED's will determine the number of cycles (number of times) a program will run. Using the "TIME/<" and the "RST/^" buttons select the number of cycles you want the program to complete (0001-9999) or select four "0's" if you want the program to run continuously. Press "SET" to go to the next step.

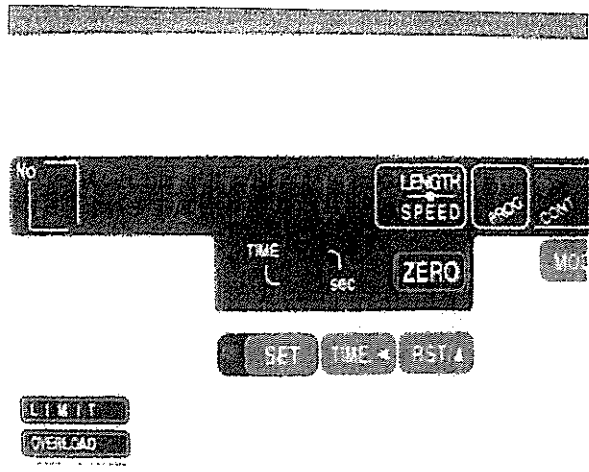

Set up for continuous cycle

The letter F⁺ appears in the LED's in the "No" box. This indicates that it is ready to accept the upper force limit. Use the "TIME/<" and "RST/^" buttons to select the desired force limit.



Note: Pressing the "TIME/<" button until no digits are blinking. Allows the user to select a negative sign by pressing the "RST/^" button.

With no negative sign displayed, the test stand platform is programmed to move downward. With the negative sign displayed, the test stand platform will move upward. Press "SET" to store the upper force limit in memory. The down arrow LED (F_▼) will light, indicating that the test stand is ready to have its lower force limit programmed. Program the force limit using the "TIME/>" and "RST/^" buttons.

Note: The upper force limit must be greater than the lower force limit ($F_{upper} > F_{lower}$). Again press "SET" to store the lower force limit into memory. You may delay the time between upward and downward movements by selecting 0, 1, 2, 3, 4 or 5 seconds using the "TIME/>" button. You may view distance traveled by pressing "LENGTH/SPEED" until the LED adjacent "LENGTH" is lit. Speed can be displayed by pressing "LENGTH/SPEED" until the LED adjacent to the indicator "SPEED" is lit. Finally, the number of cycles completed can be displayed by pressing "LENGTH/SPEED" until no LED's are lit.



Note: An RS232C output is produced when using this mode of operation; see RS232C Output Section 6.0 for details.

5.5 PROG (PROGRAM OPERATION)

Press the "MODE" key until the light emitting diode, LED, adjacent "PROG" is lit.

Length, speed or cycle count can be displayed as described in 5.3 SING mode of operation.

Cycles

To begin programming the test stand, press the "SET" key. The display will indicate a "C" in the "No" box. The "C" designates that the digits programmed into the adjacent LED's will determine the number of cycles (number of times) a program will run. Using the "TIME/<" and the "RST/^" buttons select the number of cycles you want the program to complete (0001-9999) or select four "0's" if you want the program to run continuously. Press "SET" to go to the next step.

Entering four zeros on cycle allows the test stand to perform the same programmed test continuously until one of the three events occurs. Stop Button is pressed, emergency stop buttons is pressed, or an overload condition is detected.

Force Limits

The display in "No" box now shows "F◀▶". The two arrows adjacent the "F" indicates that the test stand is ready to accept compression or tension force limits. To program a force, use the "TIME/<" and "RST/^" buttons to select a force value, and then press "SET".

Home Position

The display in "No" box now shows "H". The "H" designates the home position. Select "PUSH" or "PULL" button to set the HOME position. Press "SET". The test stand platform will automatically move to the selected home direction, it will travel the set distance until the limit switch is activated.

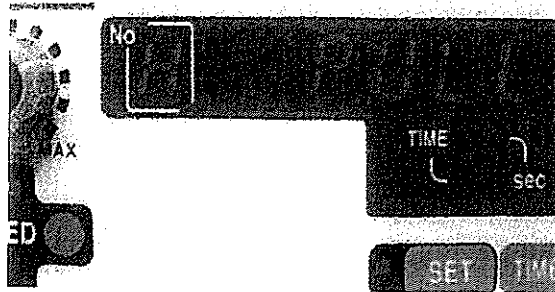

Home position set to pull direction. Test stand will look for the lower limit knob

Force "Zero"

The display in "No" box now shows "F". The "F" designates the auto zero function. This function is only available when using the Shimpo force gauge models FGC/P. Use the "TIME/<" and "RST/^" buttons to program the "zero" force.



Note: The recommended minimum zero force that the user should program into the test stand is 0.2% of the full scale (rating of the force gauge), i.e. if the programmer is using an FGC-50B force gauge, the programmed "zero" force should be 0.1-lb ($0.002 \times 50 = 0.1$).

If no force is programmed in this step and the display reads all zeros, the test stand will not zero the distance and this feature is inoperative.

Press the "SET" button to move on to the next step. This is a very useful function that allows the operator to reset the distance display and RS232 output data to zero once the force gauge senses a force measurement.

Tare

The display in the "No" box now shows "t". The "t" designates the tare function at "0" position. Select "on" or "off" by using the "RST/^" button and press the "SET" button.



The tare function allows the user to use attachments on the force gauge and then set the force gauge display to zero. This function is useful as some attachments weigh more than others and this function sets the display to zero, provided that the attachment does not weigh more than 50% of the gauge's capacity.

Note: Shimpo recommends taring not more than 20% of the gauge's rated capacity; this guarantees the availability of the force gauge full capacity.

The display in the "No" box shows "0", and the "LENGTH, SPEED, CYCLE" display shows "----". The "0" designates that the test stand begins each cycle from this position. Using the "PUSH" or "PULL" and the "SPEED A" or "SPEED B" buttons, adjust the test stand to the position from which the force gauge will begin force/distance tests. A time delay (pause) up to 5 seconds can be programmed between programmed points. Use the "TIME/<" button to cycle through "0", "1", "2", "3", "4", "5" or "P". If "P" is selected, the user must press "PROG START" key to restart the test stand program. **Position "0" is called the set point zero position, the test stand will return to this position at the beginning of each cycle.** The force gauge will also tell the test stand to stop and return to the set point 0 if a programmed force limit is reached. If the force gauge never reaches a programmed force limit, the test stand will execute an entire cycle and return to the set point zero position and then begin the next cycle. To delete an unwanted position, press "RST/^". Press the "SET" key to move on to the next programming step.



The force gauge plate will only go back to HOME position after all the cycles are completed. Each cycle returns to point zero position.

The display in the "No" box shows "1", and the "LENGTH, SPEED, CYCLE" display shows "----". The "1" designates the next position of a cycle that the test stand will move to. This position is defined as set point 1. Ensure that the correct LED indicator for "Speed A" or "Speed B" is illuminated so that the test stand will travel at the intended speed. (see photo)

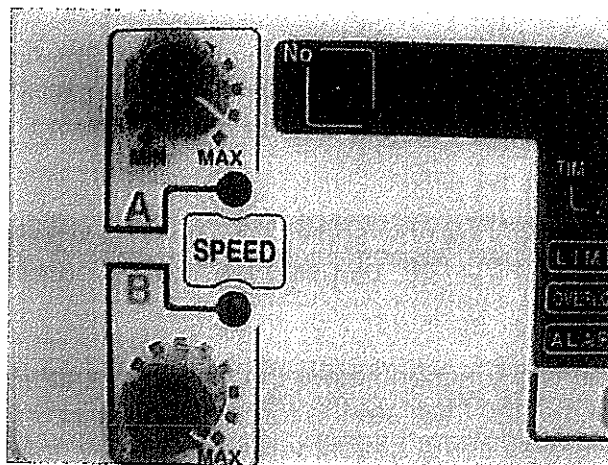

Speed knob A and B. Desired speed can be selected by pressing the "Speed" Button.

Using the "PUSH" or "PULL" button move the test stand platform to position 1.
Note: If the programmed force limit is detected by the force gauge, the test stand will not move through the entire programmed distance and the force gauge will return to set point zero. Press the "SET" key.

The display in the "No" box shows "2", and the "LENGTH, SPEED, CYCLE" display shows "----". The "2" designates the next position of a cycle that the test stand will move to. This position is defined as set point 2. Using the "PUSH" or "PULL" and the "SPEED A" or "SPEED B" control knobs move the force gauge to position 2



Note: If the programmed force limit is detected by the force gauge the test stand will not move the entire programmed distance and the force gauge will return to set point zero.

Press the "SET" key.

The display in "No" box shows "3", and the "LENGTH, SPEED, CYCLE" display shows "----". Repeat these steps outlined in the above paragraph up to a maximum of 5 points.

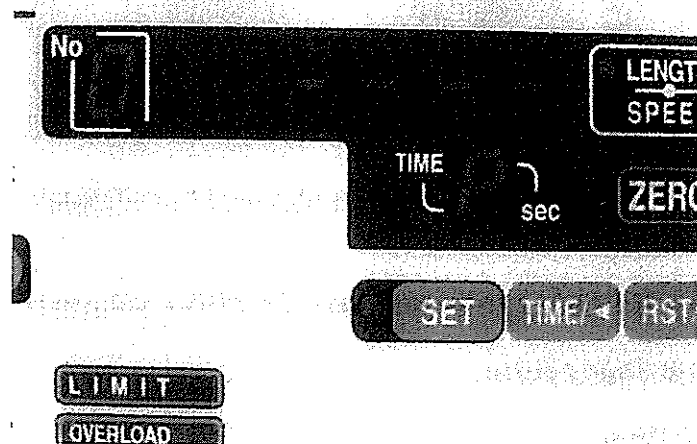

Shown point zero ready to accept entry. Use push and pull button to increment and decrement value.

If no more steps are desired, press the "SET" key while the "LENGTH, SPEED, CYCLE" display shows "----" to finish programming the test stand.



It is not necessary to provide entries for all the set points. The test stand will work with one set point.

If more than two set points are entered and a change of the second value is required, please re-enter the set points for both entries. The distances for the test stand program are accumulative, and dependent on the previous set point.

Run the program by selecting "PROG START" on the display panel.



To reset the program memory, press and hold "RST/^" and then press "SET". The display will read "CCCC".

Note: An RS232C output is produced when using this mode of operation, see RS232C Output Section 6.0 for details.

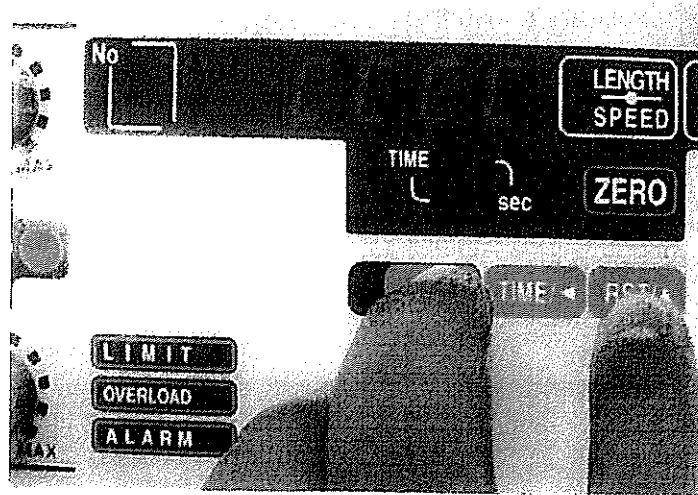

Clearing the previously stored program helps in eliminating program conflicts.

6.0 RS232C Output Format (using FGCIFGP Force Gauges)

Cr means carriage return

SING/CONT Mode

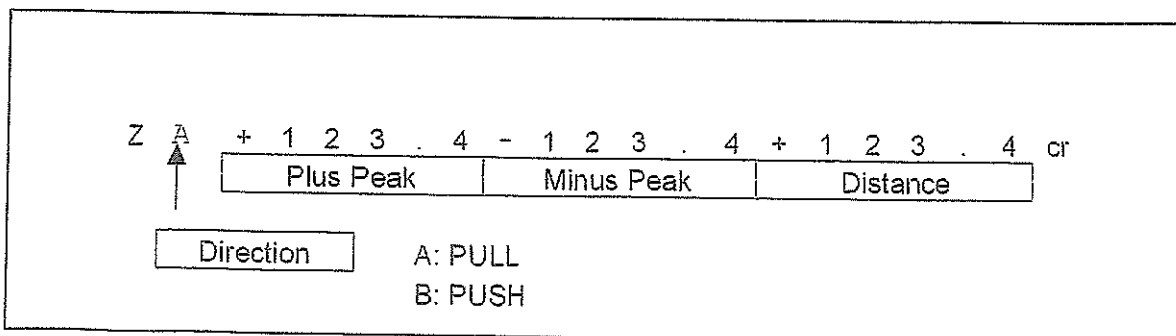

NOTE: Direction A: PULL, B: PUSH

Data will be outputted when stand platform reaches a manual limit switch or a programmed force limit.

PROG Mode

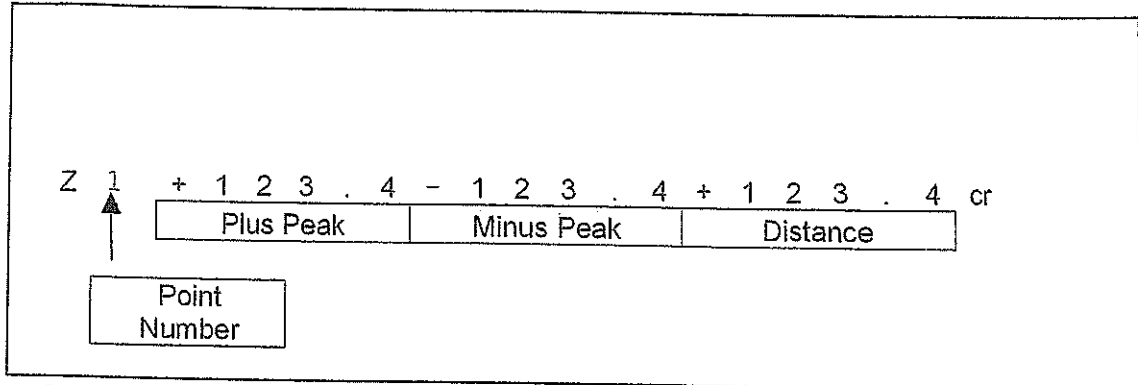

Data will be sent when the test stand platform reaches every set position or if force gauge exceeds the force limit.

Note: If the auto zero function is selected, data will be outputted at the first zero position, when the test stand platform reaches every set position or if the force gauge exceeds a force limit.

“CR” means carriage return or Enter

7.0 Troubleshooting

Stand does not turn on

- Check all electrical components (power source, power cord, fuse, power switch, emergency cut-off switch)
- The mounting plate (force gauge) does not move:
- Check manual limit knobs and adjust accordingly
- Check to see if the full travel range has already been achieved
- Check to be sure that you are in the correct operating mode.

Set force set points are not stopping the stand

- Make sure communication exists between the force gauge and the test stand
- Check if the right cable is attached
- Check if the proper baud rate for communication is set from the force gauge (required baud rate 19200 baud rate for FGC/FGP Communication with FGX force gauges bypasses the test stand to the PC, using the special cable.

Display indicates “no_F” after power up

- Check force gauge cable (only for FGC and FGP models)
- Check for proper baud rate from the force gauge
- Reset the whole system, powering up in this particular order Force Gauge>Test Stand

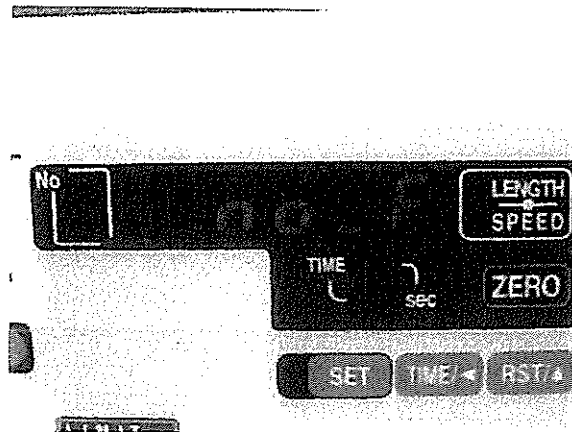

Initialization takes longer and a no_F display indicates there is no communication established between the test stand and the force gauge.

FGX models can transfer data directly using the special cable Length and distance of the test is programmed from the test stand.

Limit switch not stopping the test stand/ force gauge from moving
Check if the limit switch shoe behind the knob has been turned in the wrong position. (See photos for proper orientation and installation)

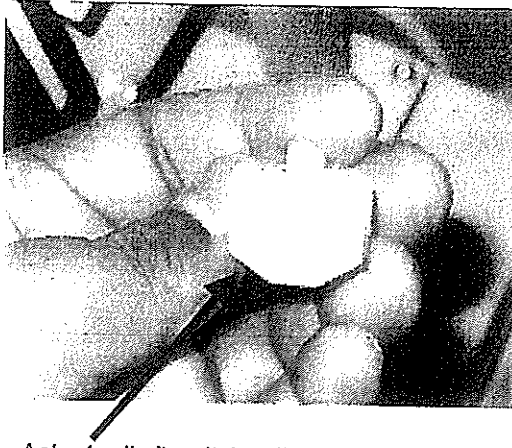

Actuator limit switch rollers should hit this side of the limit switch .

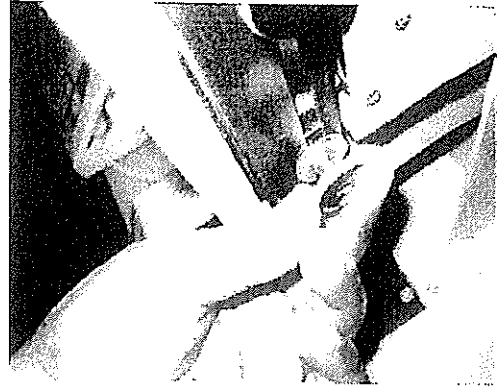

Insert the washer before the knob

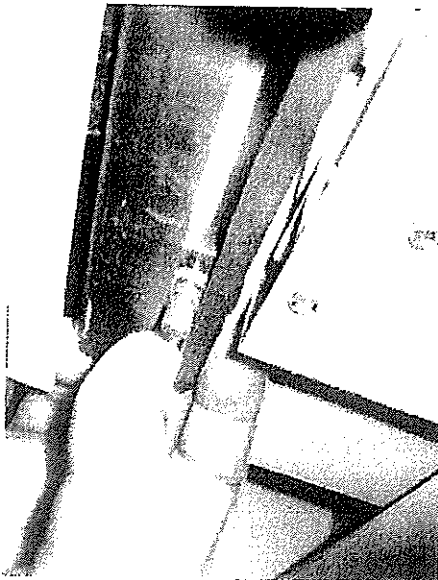

The limit switch shoe has a lip guide preventing it from spinning. Orient the Limit switch shoe properly before installation.

Getting wrong distance for test

- Re-enter all the test points distances (Remember that the distance is dependent on previous set points, points are accumulative).
- Check if a force limit is set in memory.

RS-232 output not working correctly

- Check if the proper cable is selected and attached to the force gauge.

8.0 Test Stand Specifications

Model		FGS-50VB-L	FGS-50VB-H
		Low speed	High speed
Capacity		110 LB (500N, 50kgf)	
Travel speed		5 - 120mm/min	20 - 500mm/min
		2 types of speed switch	
Stroke		140mm(with mechanical backlash 0.2 - 0.5mm)	
Display	Speed	5.0 - 120.0mm/min	20.0 - 500.0mm/min
	Distance	0.0 - 140.0mm	
	Repetition number	0-9999	
Operation mode		Manual, Inching, Single cycle, Continuous cycling, Program mode,	
Output signal	Analog voltage	Output the displacement of the stand 10mV/mm MAX: ±1.4V	
	RS-232C	Yes	
Input	Overload input	Stop the operation of the stand due to the overload of FGX FGC and FGP	
Alarm		Stop the motor due to the motor overload of the stand.	
Hight adjustment range		61-181mm (5levels per 30mm)	
Measuring table		150×145mm	
Operation Temperature		0-45C (non condensing)	
Power supply		AC 110V	
Weight		23kg	
Accessories		Power AC socket for force gauge, connection cable for FGP and FGC, analog output cable.	
Others		Emergency stop button	

9.0 Dimensions and Drawings

Test Stand Dimensions

Additional clearance available in six 30 mm increments

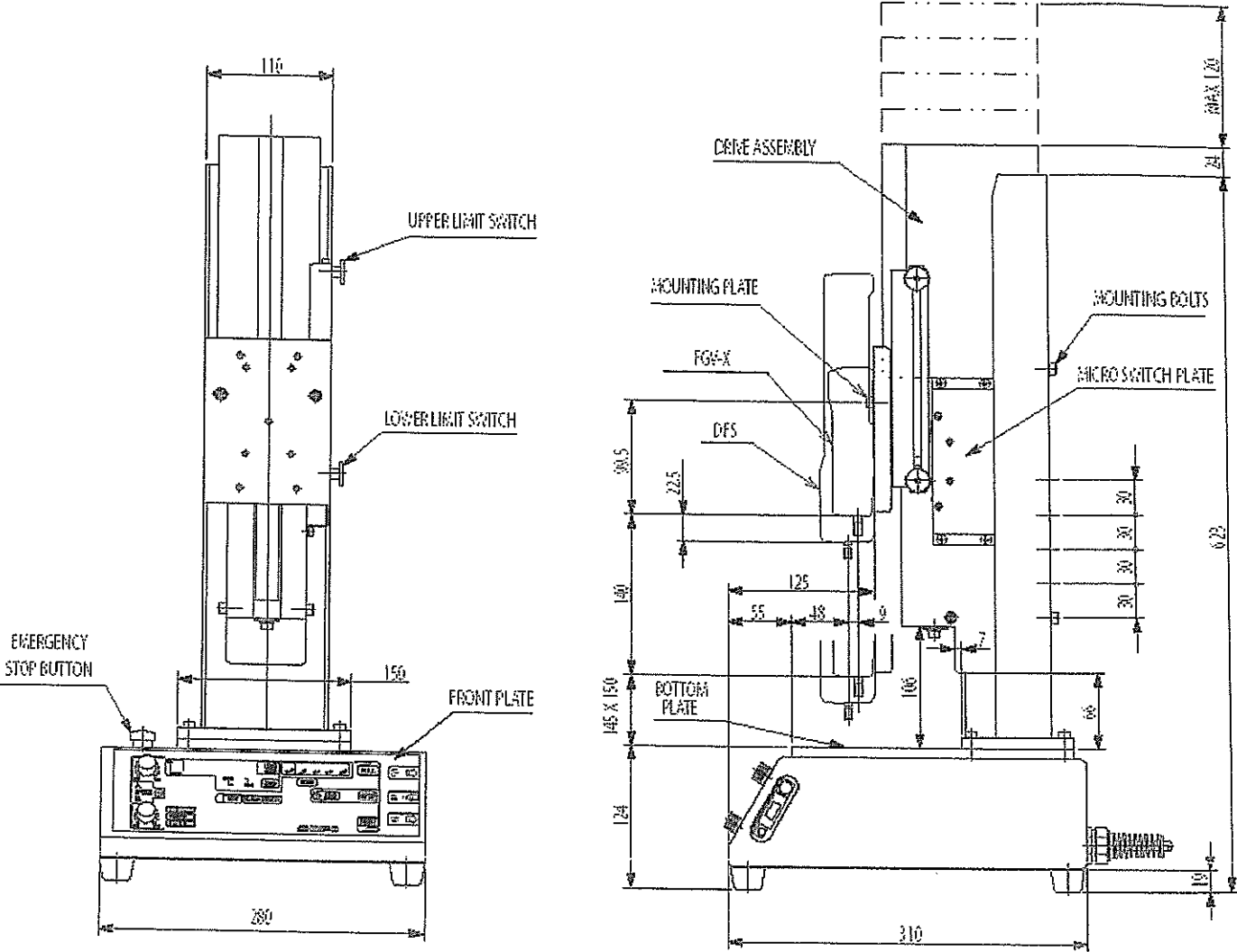

All Dimensions are in mm units.

Bottom Plate Dimensions

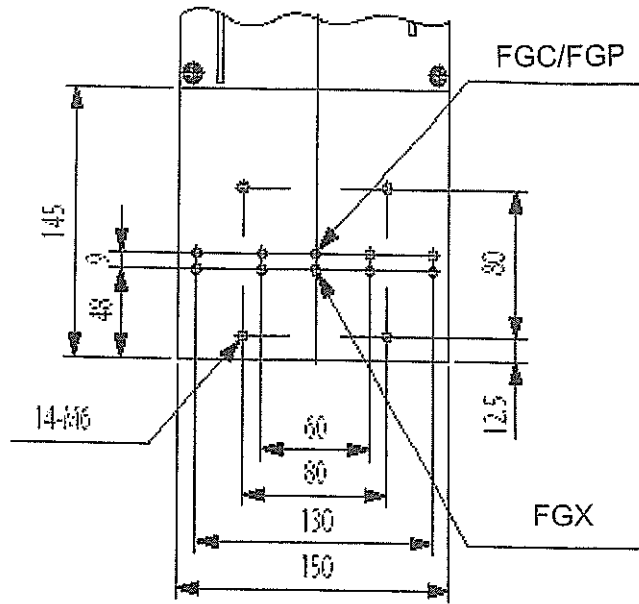

Force Gauge Mounting Plate Dimensions

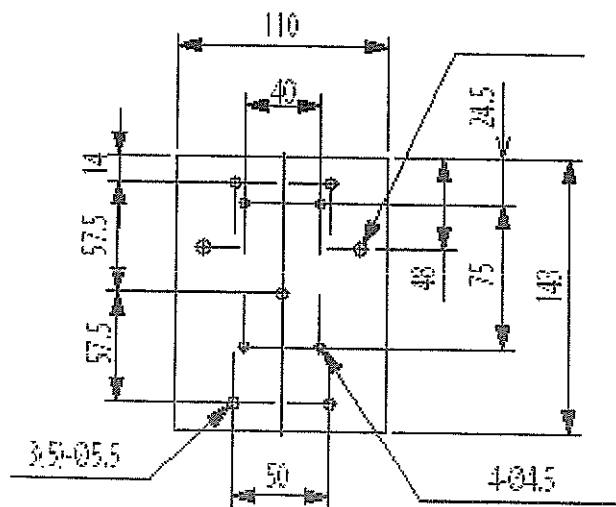

Manufactured by

NIDEC-SHIMPO CORPORATION

1 Terada, Kohtari, Nagaokakyo-city, Kyoto, Japan

Phone: (075)958-3608 Fax: (075)958-3647