

Digital Force Gauges

Models FGN-B

Models FGC-B

INSTRUCTION MANUAL

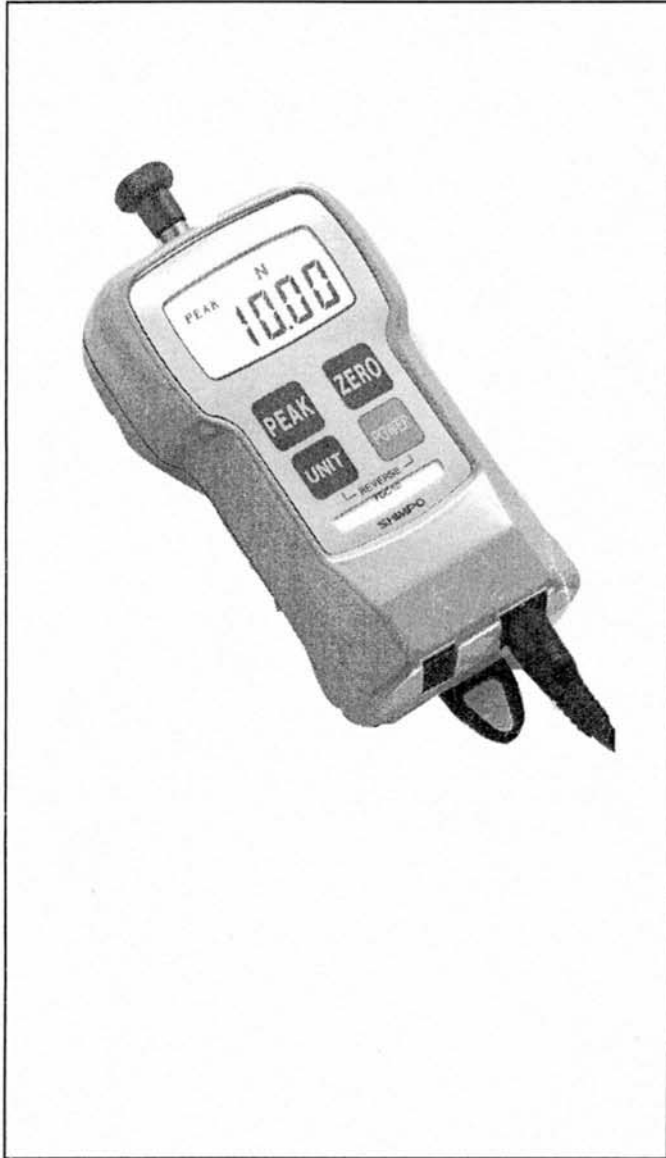

Congratulations on your purchase of a Shimpo FGC/C-B series digital force gauge. We trust you will enjoy many years of professional results from your Shimpo product.

Please read the entire instruction manual thoroughly before initial set-up and operation; the information contained herein will aid you in operating your Shimpo digital force gauge safely and with excellent results.

If you have any questions regarding our product(s), call your local Shimpo representative or contact Shimpo directly for assistance.

Inspection/Standard Accessories

If upon delivery shipping damage is detected, do not operate the unit. Notify shipping carrier immediately for damage claim instructions. Refer to nameplate and record serial number for future reference. Items included with the unit are:

- Carrying case
- Standard adapter set (hook, chisel, flat head, notched head, cone head, extension rod)
- Hanger
- RS-232C cable (FGC-B series only)
- AC charger/adaptor

Features and Benefits

Shimpo digital force gauges offer many features and benefits, including:

- 1,000 Hz update rate for capturing highest peaks
- Aluminum construction provides exceptional durability
- An ergonomically designed digital instrument to fit perfectly in the palm of your hand
- Single touch, measure force in lb, Kg and N (oz/gram for 0.2B, 0.5B, 1B) engineering units
- When gauge is placed on a test stand or if the hanger is used, display may be reversed with push buttons so that it can be read right side up.
- High accuracy ($\pm 0.2\%$ F.S.) is ideal for QC inspection and process control
- RS-232C and Analog output (FGC-B series only)

Safety Precautions



Do not operate or store instrument in the following places: explosive areas; near water, oil, dust, or chemicals; areas where temperature is above 40°C.



When not in use, place gauge back in its case to prevent damage due to accidental drop etc. With a little care you can have an instrument that will provide service for many years.



Do not disassemble or repair unit while in operation.

Physical Features

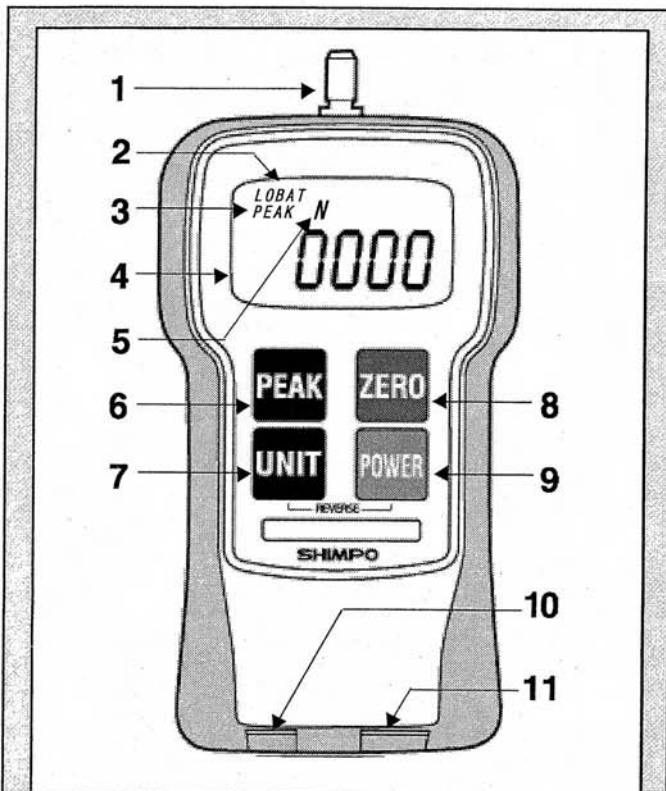

NO.	DESIGNATION
1.	Sensor Shaft
2.	Low Battery Indicator
3.	Peak Indicator
4.	Main Display
5.	Small Display
6.	Peak Button
7.	Unit Button
8.	Tare and Zero Button
9.	Power (ON, OFF) switch
10.	AC Adapter Port
11.	Data Output Port

Factory Setting

The FGN/C-B will revert to factory setting when the gauge is first powered on. Consult the "Function Setting" section to customize these default settings.

The following chart reflects the default settings as programmed by the factory:

FUNCTION NUMBER	DESCRIPTION	DEFAULT FACTORY SETTING
f01	Plus or Minus sign	0001 (plus for compression)
f02	Display update time	3 (3 times/sec)
f03	Auto power off	10 (min)
f04(FGC-B)	Baud rate of RS-232C	2400 (bps)

Operation

1. Charge the batteries for approximately 12 hours before using the gauge (Batteries come discharged from the factory). The BAT indicator is on when batteries are charging, off when the batteries are fully charged.
2. Hand tighten appropriate attachment to unit's measuring shaft (do not use a wrench or any other device to tighten the attachment).
3. Press POWER and release. The unit will display model name in small display and capacity in main display and then will show some zeros with the last one or two digits changing to some random numbers. Also the unit of measurement (lb (oz), Kg (g) or N) will appear above the digits and stay as long as the instrument is on.

Change Display Units

To change the display units, just press UNIT and the units will change every time the button is pressed.

lb (oz) → N → Kg (g) →

Reverse the Display

If unit is used with the hanger or mounted on a test stand and the display must be reversed, follow this procedure:

1. Press POWER and hold it; display will go blank.
2. Press and hold UNIT.
3. Release POWER while you are still holding UNIT; display is still blank.
4. Press POWER once more and release it while still holding UNIT. At this point you should see the display reversed.
5. Release UNIT; the display stays in that mode.

To go back to normal mode repeat steps 1 through 5.

Select Average or Peak

If you want to measure force in real time (average) the display will show only the digits and units of the force being measured. If you want to measure Peak force:

1. Press PEAK; the word PEAK will appear in the upper left corner of the display. (If you need a minus peak, press PEAK again.)
2. The display will freeze after capturing the peak force.
3. Press ZERO to cancel previous peak and continue with your tests.

If you want to go back to average mode press PEAK again. The word PEAK will disappear from the display.

NOTE: It is very important that you measure forces (tension or compression) that are in line with the measuring shaft and not at any angle (see fig. 1). Failure to observe this directive will damage the instrument. Also, after the gauge is positioned and ready to take a measurement (with the proper attachment in place) tare the unit by pressing ZERO. To clear the display for another measurement (in PEAK mode), press ZERO.

Tension Measurement

To measure tensile force, use the hook attachment. The display will show the force measured and a minus sign (-) will appear on the left of the display (to the left of the digits).

NOTE: To display no sign (plus) for tensile force, consult the Function Setting" section.

Compression Measurement

To measure compression force, use the flat head attachment. No sign will appear on the left of the display during a compression measurement.

NOTE: To display minus sign (-) for compression force, consult the Function Setting" section.

Low Battery

When battery charge is low, LO BAT will appear on the display indicating the batteries need to be charged. Charging time of fully depleted batteries is approximately 18 hours when the unit is off. The adapter/charger automatically shuts off when the battery is at full charge to protect the battery.

Note: The adapter/charger can be used to power the unit during battery charging, but will lengthen charging time.

Auto Power Off

If the gauge is on and there is no activity for 10 minutes, the unit automatically powers off to conserve battery charge. PWR appears above the display digits to notify that there is 1 minute before power off. If the adapter/charger is powering the gauge, auto power off function becomes inactive.

NOTE: To modify the auto power off function, consult the Function Setting" section.

Tracking Function

A tracking function has been introduced to check and compensate for temperature drift. When measuring very minute forces (a few ounces or grams) and at a very slow rate, you may want to turn off the tracking function.

To turn the tracking function off, follow the steps below:

1. Turn POWER off.
2. Press PEAK and UNIT switches simultaneously and hold, then press and release POWER (If tracking function was on, the display will show TRK OFF momentarily)
3. Release PEAK and UNIT.

The tracking function is now off. Repeat above steps to turn it on. The gauge will display TRK SET when turned on. It is a good idea to have this function on at all the times unless it is absolutely necessary to cancel it.

External Device Communications

When operated with the appropriate output cable, the FGC-B offers output capabilities.

Overload

Even though each model is able to withstand an overload of 200% of its rated capacity, caution should be exercised that this does not happen, otherwise the sensor will be damaged. To protect the gauge and/or the sample under test when a motorized stand or some other device is used in conjunction with the gauge, two overload output OC NPN transistors are available to be used to disconnect power when the overload condition reaches 120% of the gauge's rated capacity. One transistor is for tension and the other for compression. See figure 2.

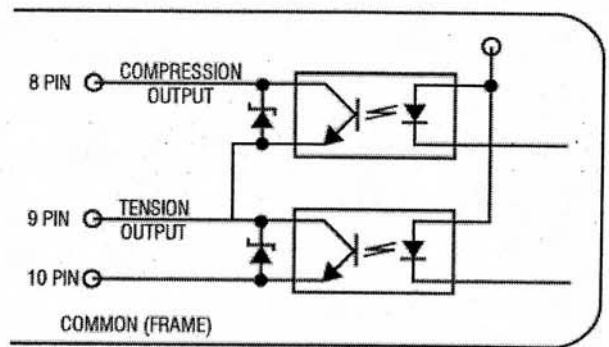

Fig. 2

An analog output signal is available for recording purposes. The amplitude of this signal is ± 1 VDC. The voltage is positive when compression testing is performed and negative for tension. The signal characteristics are as follows:

Amplitude	± 1 VDC
Generated by	12-bit D/A converter
Signal update	100 times/sec (update every 10 msec)
Load impedance	10 KΩ minimum
Connector pins	Pin #1 signal output (analog) Pin #2 GND (analog)
	(see Fig.3 & Table 1)

NOTE: When the zero switch is pressed to tare the gauge the analog output goes to 0V automatically.

RS-232C Port

An important feature of the FGC-B family of gauges is the RS232C communications port. Data and commands can be linked to a PC or any other device responding to RS232C signals for storage or further analysis. Table 1 (below) describes the function of each pin of the connector (HR12-10RC-10SDL) shown in Fig. 3.

PIN#	DESCRIPTION
1	Analog signal output
2	Analog GND
3	Receive data (input)
4	Digital GND
5	Communication enable
6	Transmit data (output)
7	No connection
8	Compression overload output
9	Tension overload output
10	Frame GND

Table 1

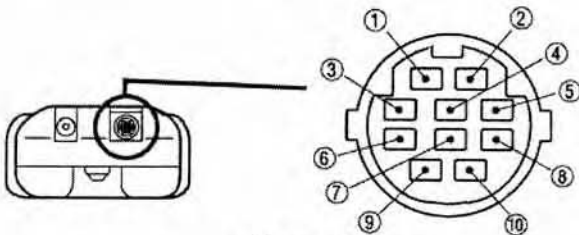

Figure 3
(HR12-10RC-10SDL), HIROSE

RS232C Output Specifications

Baud rate	2400, 4800, 9600, 19200 bps (selectable)
Data length	8 bits
Parity	None
Stop bit	One

Commands/Responses

The FGC-B series of force gauges has the ability to recognize and respond to various commands from outside peripherals. If for instance the gauge receives a legitimate command from a PC, it will respond by sending back the same code indicating to the PC that the command was recognized. If for example the command is a request for average data output, it will send the data and the code NA etc. If the gauge recognizes an error while it is receiving a command, an error symbol is transmitted back to the PC indicating the exact nature of the error.

Commands to FGC-B Gauge

AAcr	Tare
ABcr	Stop output
ACcr	Change to peak mode
ADcr	Change to average mode
AEcr	Peak reset
AFcr	Change units to Kg (g)
AGcr	Change units to N
AHcr	Change units to lb (oz)
BAcr	Data output request (single reading)
BBcr	Continuous data output request (10 times/sec)
BB1cr	Continuous data output request (20 times/sec)
BB2cr	Continuous data output request (50 times/sec)
BB3cr	Continuous data output request (100 times sec)
BCcr	Model name confirmation request
BDcr	Units confirmation request
BEcr	Peak data output request
BFcr	Minus Peak data output request
cr	(cr: carriage return)

Response from FGC-B gauge

NA□□□□□cr	Average data output
NB□□□□□cr	Peak data output
	4-digit number with decimal point
	sign (+ or -)
NE□□cr	Model number
	02 = FGC-0.2B
	03 = FGC-0.5B
	04 = FGC-1B
	05 = FGC-2B
	06 = FGC-5B
	07 = FGC-10B
	08 = FGC-20B
	09 = FGC-50B
NH□cr	Unit
	0 = N
	1 = Kg (g)
	2 = lb (oz)

Error Symbols

OBcr	Command error
OEcr	Parity error
OFcr	Format error
OGcr	Summing error
OHcr	Overrun error

Function Setting

The FGN/C-B will default to certain parameters when power is turned OFF and ON. To access the function setting:

1. Press and hold the ZERO button.
2. Press and release the POWER button.
3. Each time the PEAK button is pressed, the FGN/C-B will scroll through each of the functions.
4. Press the ZERO button to exit.

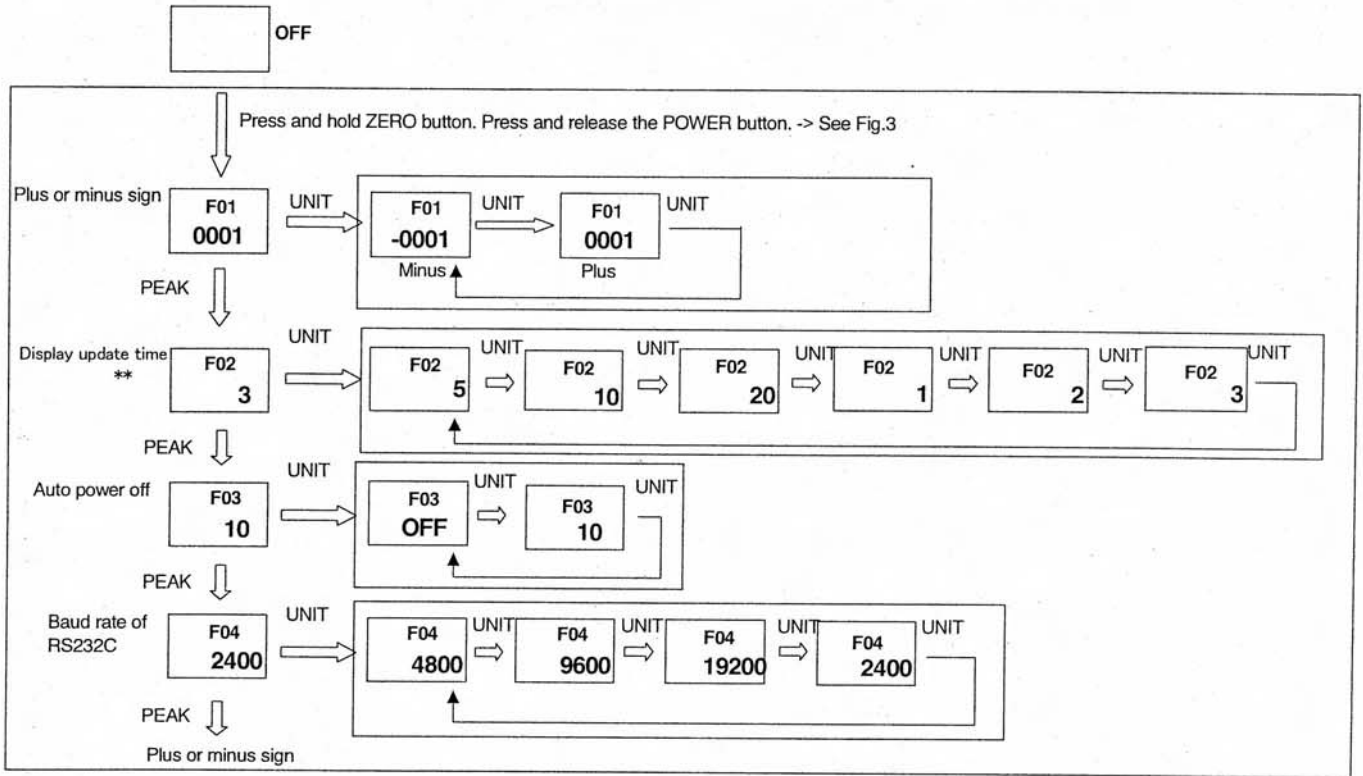

**Note: In function 2, the numbers signify as follows.

1; 1 time/sec, 2; 2 times/sec, 3; 3 times/sec, 5; 5 times/sec, 10; 10 times/sec, 20; 20 times/sec

↓ ZERO
Data is memorized

Calibration

1. A secure calibration stand to mount a force gauge upside-down.
2. The appropriate calibration weight for your force gauge. (Metric only!)

MODEL	CODE	WEIGHT
FGC-0.2B	02	200 g
FGC-0.5B	03	500g
FGC-1B	04	1Kg
FGN/C-2B	05	2Kg
FGN/C-5B	06	5Kg
FGC-10B	07	10Kg
FGN/C-20B	08	20Kg
FGN/C-50B	09	50Kg

3. Turn POWER off.
4. Mount the force gauge upside down on the calibration stand.
5. Attach the fixture on the sensing shaft of the force gauge, carefully threading it finger tight.
6. Press and hold the UNIT, PEAK and ZERO switches.
7. Press and release the POWER switch (while continuing to press UNIT, PEAK and ZERO) until the smaller characters at the top of area of the display show CAL. Release the UNIT, PEAK and ZERO switches. The force gauge is now in calibration mode.

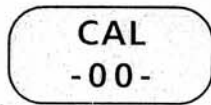

8. Press the UNIT switch. The display will show ZER after blinking SCN for 10 seconds. The force gauge is now ready for zero point calibration.



9. Press ZERO to zero calibrate. Wait approx. 17 seconds. The display will change to show PEK after blinking SCN. Do not press any other switches or move the sensing shaft during calibration.

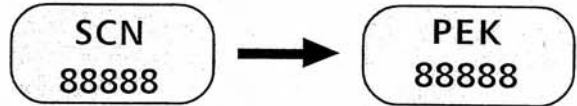

10. Hang the calibration weight on the hook and stabilize; the larger characters on the display will change. The force gauge is now ready for full-scale calibration.
11. Press the PEAK switch to begin full scale calibration. Display blink SCN. Do not press any other keys or touch the weight during calibration. After approx. 17 seconds the display blinks END, then after approx. 5 seconds the display blinks OK.

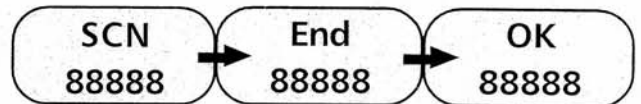

12. If calibration was successful, the display will show OK momentarily (see above picture.). Press the UNIT switch, then automatically power off.
13. If calibration was unsuccessful, the display will show ERR. Remove the calibration weight, then press UNIT switch. Repeat the procedure 6-9.

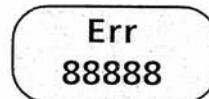

Troubleshooting

The following are general checkpoints; please call your local Shimpo representative or contact Shimpo Instruments directly for further assistance.

The force gauge does not come on:

- Check all electrical components (power source, charged battery or AC adaptor connected)

The stand does recognize the RS232 output/input:

- Check all connections between the test stand and the force gauge and/or computer

Error codes are displayed:

- Turn unit off, then back on. If error codes are still displayed, see table below:

Small display	Condition	Action
	Minus side overload condition - possible load cell damage	Remove excessive load; if the display does not return to normal operation, send unit in for repair
	Plus side overload condition - possible load cell damage	
	The load exceeds 120% of its capacity	Remove excessive load
	EEPROM reading error	Turn off, then turn on again. If the display does not return to normal operation, send unit in for repair.
	EEPROM writing error	

Dimensions

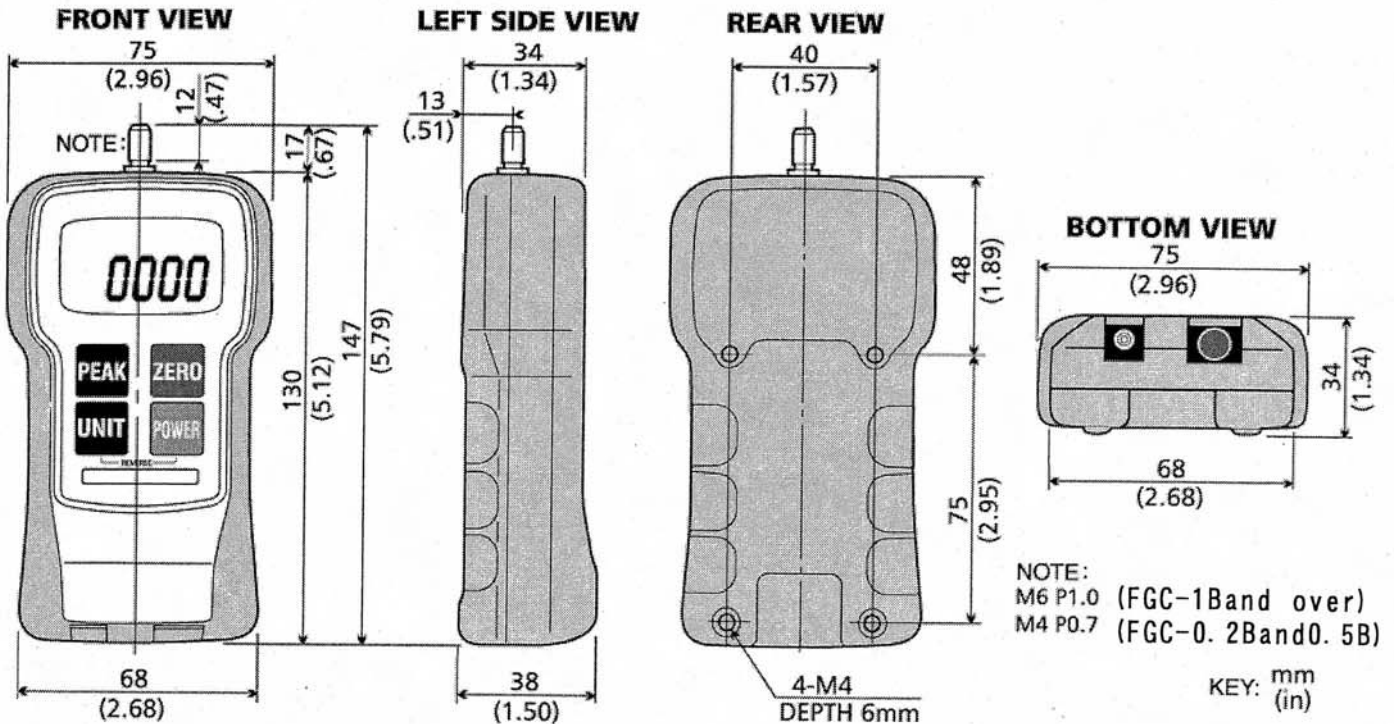

Specifications

FGC-B Model	FGC-0.2B	FGC-0.5B	FGC-1B	FGC-2B	FGC-5B	FGC-10B	FGC-20B	FGC-50B
FGN-B Model				FGN-2B	FGN-5B		FGN-20B	FGN-50B
Capacity	8 oz 200.0 g 2.000 N	16 oz 500.0 g 5.000 N	2 lb 1,000 g 10.00 N	5 lb 2.000 Kg 20.00 N	10 lb 5.000 Kg 50.00 N	20 lb 10.00 Kg 100.0 N	50 lb 20.00 Kg 200.0 N	100 lb 50.00 Kg 500.0 N
Resolution	0.01 oz 0.1 g 0.001 N	0.01 oz 0.1 g 0.001 N	0.001 lb 1 g 0.01 N	0.001 lb 0.001 kg 0.01 N	0.01 lb 0.001 kg 0.01 N	0.01 lb 0.01 kg 0.1 N	0.01 lb 0.01 kg 0.1 N	0.1 lb 0.01 kg 0.1 N
Accuracy	± 0.2% f.s.							
Display	4-Digit LCD, 12mm high. Reversible by the push of a button. Minus sign for tension.							
Display Update	0.05, 0.1, 0.2, 0.3, 0.5, 1 sec							
Sampling Rate	1000 times per second							
Overload	200% of f.s.							
Power	Rechargeable Ni-Cad battery or AC through adapter/charger							
Output (FGV only)	Analog: ±1VDC (through a 12 bit D/A converter) RS232C: Baud rate (19200, 9600, 4800, 2400 bps selectable), commands control							
Auto Power Shut-Off	Yes (not active if adapter/charge is in use)							
Battery Life	8 hours (when fully charged)							
Recharge Time	Approximately 12 hours when fully discharged							
Temperature	0° - 40°C							
Dimensions	130 mm x 75 mm x 38 mm							
Weight	450 g							
Standard Accessories	AC adapter/charger, carrying case, hook, chisel, flat head, notched head, hanger, cone head, extension rod, RS232C cable (FGC- B only)							
Approvals	CE approved							

NIDEC-SHIMPO CORPORATION

1 Terada, Kohtari, Nagaokakyo-city, Kyoto, Japan

Phone: (075)958-3608 Fax: (075)958-3647